INSTRUCTION MANUAL

AC LINE REGENERATIVE MODULE 15 HP TO 1750 HP



Thank You

We at US Drives, Inc. would like to say thank you for purchasing our product. We believe the Regenerative Module Series is the most problem free product in the market today. If you have any questions or comments please feel free to call us. On behalf of all of us here once again thank you.

Recording Drive Information

It is a good idea to record all product nameplate information for future reference. The nameplate is usually mounted on the side of the unit. The following tables should be filled in during starting or prior to starting the module.

Part Number P/N	
Serial Number S/N	
Software Revision Level SRL	

Branch Circuit Protection

Branch circuit protection must be provided by the end user. In this manual you will find recommended fuse sizes and types for each module size.

Mounting Location

The unit should be installed in a well ventilated, moisture free area. If there are: fumes; vapors; dirt; lint; liquids or gases that can interact with the module, then a clean air supply must be provided. The ambient temperature should not exceed the range of 14 F to 131 F (-10 C to 55 C). If the unit will be subject to vibration then the enclosure should be shock mounted.

Safety Warnings

Regenerative modules, like all electrical equipment in industry, if not properly installed and operated can cause personal injury. Always use common sense when working around electrical equipment. Make sure you read this manual **before** any work on the unit begins. Never work on this product if you are tired or under the influence of any drug. The unit must be grounded and installed in accordance with National Electrical Codes (NEC) and any local codes. Make sure that all power is disconnected, before working on the module. **Always** measure the incoming voltage at the unit to make sure it is zero after disconnecting the power. Make sure all air passages are clear for proper cooling. After the unit is energized lethal voltages are present. **Wait at least 5 minutes after disconnecting power before working on the module**, since high voltages will still be present. Call us if you have any questions.

Maintenance

If the enclosure is subject to foreign material, clean the enclosure and check any filters for build up of debris. If the inside of the enclosure needs cleaning, a low pressure vacuum cleaner is recommended. Do not use an air hose because of the possible oil vapor in the compressed air and its high pressure.

OBJECTIVES

The purpose of this manual is to provide the user with the necessary information to install, start-up and maintain the *AC REGEN*. This manual should be read thoroughly before operating, servicing or setting up the *AC REGEN*.

This manual is intended for qualified service personnel responsible for setting up and servicing the *AC REGEN*. You must have previous experience with and a basic understanding of electrical terminology, programming procedures and required equipment and safety precautions before attempting service on the *AC REGEN*.

SAFETY

WARNING

Only personnel familiar with motor drives and the associated machinery should plan or implement the installation, start-up and subsequent maintenance of the *AC REGEN*. Failure to comply may result in personnel injury and/or equipment damage.

WARNING

An incorrectly applied or installed *AC REGEN* can result in component damage or a reduction in product life. Wiring or application errors such as under sizing the motor, incorrect or inadequate AC supply or excessive ambient temperatures may result in damage to the Drive or motor.

WARNING

This *AC REGEN* contains ESD (Electrostatic Discharge) sensitive parts and assemblies. Static control precautions are required when servicing or repairing this assembly. Component damage may result if ESD control procedures are not followed. If you are not familiar with static control procedures, please consult with the factory.

WARNING

TO AVOID A HAZARD OF ELECTRIC SHOCK, AFTER THE INPUT AND CONTROL POWER IS REMOVED FROM THE *AC REGEN* AND THE DRIVE CONNECTED TO IT, WAIT FIVE (5) MINUTES FOR BUS CAPACITORS TO FULLY DISCHARGE.

MODEL RATINGS

Tables 1 through 3 show the *AC REGEN* model ratings for class 200, class 400 and class 500 units.

SPECIFICATIONS AND FEATURES

Electrical Specifications:

Rated Input Voltage:	200-250Vac, 380-500Vac, 500-600Vac -10% of minimum, +10% of maximum.
Frequency Tolerance:	47-63 Hz
Number of Phases:	3
Efficiency:	99% or greater
Max. Short Circuit Current Rating:	200,000A rms symmetrical, 600 volts (when used with AC input line fuses specified in tables 1 to 3).
Noise Immunity:	IEEE C62.41-1991 Category B (Formerly known as IEEE 587) - 6000V tests EN50082-1, 2 Generic Immunity Standards IEC 1000-4-2 (IEC 801-2) IEC 1000-4-3 (IEC 801-3) IEC 1000-4-4 (IEC 801-4) IEC 1000-4-5 (IEC 801-5) IEC 1000-4-6 (IEC 801-6) IEC 1000-4-8 (IEC 801-8)

Environmental Specifications:

Ambient Temperature:	-10°C to 55°C (14°F to 131°F) Nema type 1 enclosed.
Storage Temperature:	-40°C to 70°C (-40°F to 158°F) Nema type 1 enclosed.
Altitude:	Sea level to 3000 Feet [1000m] without derating.
Humidity:	95% relative humidity non-condensing.
Vibration:	9.8m/sec ² (1.0G) peak.

Physical attributes:

Mounting:	Though hole or panel mount.
Nema Rating:	Type 1 (IP20) as standard, Type 12 (IP54) optional.
Construction:	Steel construction (reduces E.M.I.)

Control I/O:

- 2 Digital Inputs: Regen Enable & Regen Reset
- 2 Digital Outputs: Dry contacts rated 115Vac @ 5A; 30Vdc @ 3.5A.
- 24Vdc source: Use to power operator pushbuttons and US Drives, Inc. option boards: 24Vdc @ 100 mA max.

Protective Features:

- Peak output current monitoring to protect against line-to-line shorts and line-to-ground shorts.
- Ground fault monitoring.
- Heatsink over-temperature monitoring.
- AC line & DC bus over-voltage protection.
- AC line & DC bus under-voltage protection.
- Control power supply power ride-thru.
- Internal power supply monitoring.
- AC phase loss detection.

Standard Regen Features

- Latest generation IGBT.
- Nema type 1 (IP20) as standard for all models.
- 55°C ambient with standard Nema type 1 (IP20) enclosure.
- High voltage ratings: 250Vac+10% , 500Vac+10% models and 600Vac+10% models
- Input line suppression: Metal oxide varistors for line-to-line and line-to-ground voltage surge protection.
- No programming or hardware jumper for all voltages.

Table 1
Class 200 AC Regen Models (Typical Voltage 208/230/240 VAC)

200-250VAC (-10% to +10%)							
Frame Designation	NEMA 1 (IP20) Catalog Number	Continuous DC Bus Current (Amps)	Continuous Regen Power ¹ KW	Drive HP ²	AC Current (Amps)	Maximum Recommended AC Line Fuses ³ (Amps)	Total Power Losses ⁴ (W)
SIZE 1	RG-0200-0030-N1	30	11	15	29	40	176
	RG-0200-0045-N1	45	16	20	44	60	239
	RG-0200-0060-N1	60	21	30	58	90	302
	RG-0200-0090-N1	90	32	40	85	125	428
	RG-0200-0120-N1	120	42	60	116	175	554
	RG-0200-0180-N1	180	63	75	175	250	806
SIZE 2	RG-0200-0240-N1	240	84	100	233	350	1058
	RG-0200-0300-N1	300	105	125	291	450	1300
	RG-0200-0360-N1	360	126	150	349	600	1562
SIZE 3	RG-0200-0480-N1	480	168	200	466	700	2066
	RG-0200-0540-N1	540	189	250	524	900	2318
	RG-0200-0600-N1	600	210	300	582	900	2570
	RG-0200-0720-N1	720	252	350	698	1000	3074
	RG-0200-0840-N1	840	294	400	815	1200	3578
	RG-0200-0960-N1	960	336	450	931	1200	4082
	RG-0200-1080-N1	1080	378	500	1048	1500	4586
	RG-0200-1440-N1	1440	504	700	1397	2000	6098

¹ KW based on 240Vac AC Power line.

² Drive HP ratings are calculated for 230 VAC Motors based on 100% Continuous Regeneration and 150% Regeneration for 1 Minute or Less. Consult Factory for Module sizing when Regeneration requirements are less than or greater than these values.

³ Semiconductor Fuses: Ferraz Shawmut A50P, A60X, Bussmann FWH.

⁴ Total Power Loss shown is for continuous operation at full regeneration.

Table 2
Class 400 AC Regen Models (Typical Voltage 380/415/480 VAC)

380-500VAC (-10% to +10%)							
Frame Designation	NEMA 1 (IP20) Catalog Number	Continuous DC Bus Current (Amps)	Continuous Regen Power ¹ KW	Drive HP ²	AC Current (Amps)	Maximum Recommended AC Line Fuses ³ (Amps)	Total Power Losses ⁴ (W)
SIZE 1	RG-0400-0030-N1	30	21	30	29	40	200
	RG-0400-0045-N1	45	32	40	44	60	275
	RG-0400-0060-N1	60	42	60	58	90	350
	RG-0400-0090-N1	90	63	75	85	125	500
	RG-0400-0120-N1	120	84	100	116	175	650
	RG-0400-0180-N1	180	126	150	175	250	950
SIZE 2	RG-0400-0240-N1	240	168	200	233	350	1250
	RG-0400-0300-N1	300	210	300	291	450	1525
	RG-0400-0360-N1	360	252	350	349	600	1850
SIZE 3	RG-0400-0480-N1	480	336	450	466	700	2450
	RG-0400-0540-N1	540	378	500	524	900	2750
	RG-0400-0600-N1	600	420	600	582	900	3050
	RG-0400-0720-N1	720	504	700	698	1000	3650
	RG-0400-0840-N1	840	588	800	815	1200	4250
	RG-0400-0960-N1	960	672	900	931	1200	4850
	RG-0400-1080-N1	1080	756	1000	1048	1500	5450
	RG-0400-1440-N1	1440	1008	1400	1397	2000	7250

¹ KW based on 480Vac AC Power line.

² Drive HP ratings are calculated for 460 VAC Motors based on 100% Continuous Regeneration and 150% Regeneration for 1 Minute or Less. Consult Factory for Module sizing when Regeneration requirements are less than or greater than these values.

³ Semiconductor Fuses: Ferraz Shawmut A50P, A60X, Bussmann FWH.

⁴ Total Power Loss shown is for continuous operation at full regeneration.

Table 3

Class 500 AC Regen Models (Typical Voltage 525/575/600 VAC)

525-600VAC (-10% to +10%)							
Frame Designation	NEMA 1 (IP20) Catalog Number	Continuous DC Bus Current (Amps)	Continuous Regen Power ¹ KW	Drive HP ²	AC Current (Amps)	Maximum Recommended AC Line Fuses ³ (Amps)	Total Power Losses ⁴ (W)
SIZE 1	RG-0500-0030-N1	30	26	30	29	40	236
	RG-0500-0045-N1	45	39	50	44	60	329
	RG-0500-0060-N1	60	53	75	58	90	422
	RG-0500-0090-N1	90	79	100	85	125	608
	RG-0500-0120-N1	120	105	125	116	175	794
	RG-0500-0180-N1	180	158	200	175	250	1166
SIZE 2	RG-0500-0240-N1	240	210	250	233	350	1538
	RG-0500-0300-N1	300	263	350	291	450	1900
	RG-0500-0360-N1	360	315	400	349	600	2282
SIZE 3	RG-0500-0480-N1	480	420	500	466	700	3026
	RG-0500-0540-N1	540	473	600	524	900	3390
	RG-0500-0600-N1	600	525	700	582	900	3770
	RG-0500-0720-N1	720	630	800	698	1000	4514
	RG-0500-0840-N1	840	735	900	815	1200	5250
	RG-0500-0960-N1	960	840	1000	931	1200	6002
	RG-0500-1080-N1	1080	945	1300	1048	1500	6746
	RG-0500-1440-N1	1440	1260	1750	1397	2000	8978

¹ KW based on 600Vac AC Power line.² Drive HP ratings are calculated for 575 VAC Motors based on 100% Continuous Regeneration and 150% Regeneration for 1 Minute or Less. Consult Factory for Module sizing when Regeneration requirements are less than or greater than these values.³ Semiconductor Fuses: Ferraz Shawmut A70P, A60X, Bussmann FWP.⁴ Total Power Loss shown is for continuous operation at full regeneration.

INSTALLATION AND WIRING

This Section provides the information needed to properly mount and wire the *AC REGEN*. Since most start-up difficulties are the result of incorrect wiring, it is essential that the wiring is done as instructed. Read and understand this section in its entirety before actual installation begins.

WARNINGS

WARNING

Only qualified electrical personnel familiar with the construction and operation of this equipment and the hazards involved should install, adjust, operate or service this equipment.

WARNING

The control and its associated motors and operator control devices must be installed and grounded in accordance with all national and local codes (NEC, VDE 0160, BSI, etc.). To reduce the potential for electric shock, disconnect all power sources before initiating any maintenance or repairs. Keep fingers and foreign objects away from ventilation and other openings. Keep air passages clear. Potentially lethal voltages exist within the *AC REGEN* enclosure and connections. Use extreme caution during installation and start-up.

WARNING

The following information is only a guide for proper installation. US Drives, Inc. cannot assume responsibility for the compliance or noncompliance to any code, national, local or otherwise for the proper installation of this *AC REGEN* or associated equipment. A hazard of personal injury and/or equipment damage exists if codes are ignored during the installation.

INITIAL CHECKS

Before installing the *AC REGEN*, check the unit for physical damage sustained during shipment. If damaged, file a claim with the shipper and return for repair following the procedures outlined on the back cover. If no damage is observed, remove all shipping restraints and padding. Check *AC REGEN* nameplate data for conformance with the AC power source and motor.

DETERMINING CONTROL LOCATION

The *AC REGEN* is suitable for most well-ventilated factory areas where industrial equipment is installed. Locations subject to steam vapors or excessive

moisture, oil vapors, flammable or combustible vapors, chemical fumes, corrosive gases or liquids, excessive dirt, dust or lint should be avoided unless an appropriate enclosure has been supplied or a source of clean air is supplied to the enclosure. The location should be dry and the ambient temperature should not exceed 131°F (55°C). If the mounting location is subject to vibration, the unit should be shock mounted.

MOUNTING

Figure 1 shows the minimum required surrounding air space for panel mounted *AC REGEN*. Note that the panel mounted units must be mounted in an upright position. Figure 2 shows dimensional information for size 1. If through panel mounting is chosen, a suitable sealant should be applied to the mounting faces of the *AC REGEN* and the panel to prevent leakage.

Figure 1
Minimum Required Surrounding Air Space

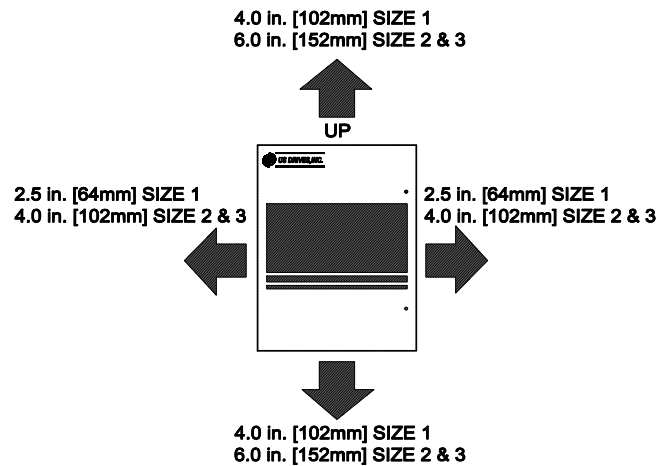

AC SUPPLY SOURCE

AC REGEN is suitable for use on a power system capable of delivering up to a maximum of 200,000 rms symmetrical amperes, 250/500/600 +10% volts maximum when used with AC input line fuses specified in tables 1, 2 and 3 respectively.

WARNING

To guard against personal injury and/or equipment damage caused by improper fusing, use only the recommended line fuses specified in tables 1, 2 and 3.

Unbalanced Distribution Systems

The *AC REGEN* is designed to operate on three-phase supply systems whose line voltages are symmetrical. Surge suppression devices are included to protect the *AC REGEN* from lightning induced over-voltages between line and ground. Where the potential exists for abnormally high phase-to-ground voltages (in excess of 125% of nominal) or where the supply ground is tied to another system or equipment that could cause the ground potential to vary with operation, suitable isolation is required for the *AC REGEN*. Where this condition exists, an isolation transformer is strongly recommended.

Ungrounded Distribution Systems

All AC Regen are equipped with MOVs that provides voltage surge protection and phase-to-phase plus phase-to-ground protection which is designed to meet IEEE 587. Where the potential exists for abnormally high phase-to-ground voltages (in excess of 125% of nominal), an isolation transformer is strongly recommended. The MOV circuit is designed for surge suppression only (transient line protection), not continuous operation. With ungrounded distribution systems, the phase-to-ground MOV connection could become a continuous current path to ground.

If the AC source for the AC Regen does not have a ground reference (neutral or phase ground), an isolation transformer with the neutral of the secondary grounded is highly recommended. These AC Regen's contain PE referenced MOV devices for input transient voltage limiting. Transients occurring on a non-ground referenced voltage source may generate excessive line to ground voltages which could exceed the limits of the insulation system of the AC Regen. Under these conditions, it is highly recommended that a system level transient voltage suppression device be employed in order to limit the potential line to ground voltage. Contact factory if the AC Regen must be operated on an ungrounded voltage source.

Input Power Conditioning

The basic guidelines for determining if an isolation transformer is required are as follows:

1. If the AC input power system does not have a neutral or one phase referenced to ground, an isolation transformer with the neutral of the secondary grounded is **highly recommended**. If the line-to-ground voltages on any phase can exceed 125% of the nominal line-to-line voltage, an isolation transformer with the neutral of the secondary grounded, is **always required**.
2. If the AC line supplying the *AC REGEN* has power factor correction capacitors that are switched in and out, an isolation transformer is

recommended between the *AC REGEN* and the capacitors.

3. If the AC line frequency experiences transient power interruptions or significant voltage spikes, an isolation transformer or a three percent (3%) reactor is recommended.

Input Fusing

WARNING

AC REGEN does not provide input power short circuit fusing. Maximum Recommended AC Line Fuses are shown in tables 1, 2 and 3. Note that branch circuit breakers or disconnect switches can not respond fast enough to provide the level of protection that the *AC REGEN* components require.

Input Devices

WARNING

Hardwired Stop Circuit

The *AC REGEN* "ENABLE" control input circuitry includes solid-state components. If hazards due to accidental contact with moving machinery or unintentional flow of liquid, gas or solids exist, an additional hardwired stop circuit is required to remove AC line power to the *AC REGEN*. When AC power is removed, the motor will coast to a stop. Consequently, an auxiliary braking method may be required.

ELECTRICAL INTERFERENCE (EMI/RFI)

AC REGEN Immunity

The immunity of the *AC REGEN'S* to externally generated interference is outstanding. No special precautions other than following the procedures outlined in this manual are required.

It is recommended that the coils of AC and DC energized contactors interfaced with the *AC REGEN* be suppressed with RC networks and diodes respectively or with similar devices. This is because non-suppressed coils (inductors) can generate high electrical transients.

In areas prone to frequent lightning strikes, the standard MOV's (Metal Oxide Varistors) supplied with the drive may need to be supplemented with additional surge suppression MOV's on the AC line feeding the drive.

AC REGEN Emissions

Care must be used in the routing of power and ground connections to the *AC REGEN* to avoid interference with sensitive equipment that may be nearby. The cable from the drive to the *AC REGEN* carries switched voltages and should be routed well clear of sensitive equipment. The ground conductor of the motor cable should be connected to the drive ground stud directly. Connecting this ground conductor to a cabinet ground point or ground bus bar may cause high frequency current to circulate in the ground system of *AC REGEN* enclosure.

GROUNDING

Refer to the "Recommended Power Wiring" diagram in figure 3 for grounding instructions. The *AC REGEN* must be connected to AC system ground using the **power ground stud(s)** provided. Ground impedance must conform to requirements of national and local industrial codes (NEC, VDE 0160, BSI, etc.) and should be inspected and tested at regular intervals. **These ground wires must have a current rating in compliance with the above mentioned national and local codes.**

Note that the *AC REGEN* signal common (**COM**) should **not** be connected to the **power ground stud** directly. If desired, **one** of these commons may be connected to **earth ground** at a single point outside the drive enclosure.

For multiple *AC REGEN* systems, if the signal common on each *AC REGEN* is to be grounded, they can be "daisy-chained" connected, using a single **COM** point on each *AC REGEN*. Note that this *AC REGEN COM* "bus" should only tie to **earth ground** at only one point.

Grounding Sensitive Circuits

It is critical to control the paths through which high frequency ground currents flow. Sensitive circuits should not share a path with such currents. Control and signal conductors should not be run near or parallel to power conductors.

Power Cabling

Input and Output power connections are made through the power terminal block and power ground stud. The actual *AC REGEN* label markings are shown in Table 4. Maximum torque values for terminal connections are also indicated on labels next to the connection points.

Table 4
Power Signal Description

Terminal	Description
GND	Power Earth Ground Stud
L1 L2 L3 AC LINE INPUT	AC Line Input Terminals
DC- DC+	DC Bus Terminals

Control and Signal Wiring

Terminal blocks TB1 and TB2 on the AC REGEN main control board are used for connecting control and signal wiring. See Figure 4 for terminal block physical location A brief summary of the terminal block assignments are shown in Table 5.

Before proceeding with any signal wiring, the following precautions for the signal conduit and wire must be followed:

Signal Conduit Requirements

- Use either rigid steel or flexible armored steel cable.
- The signal conduit must cross non-signal conduit at an angle of between 45° and 90°.
- Do not route the conduit through junction or terminal boxes that have non-signal wiring.

Signal Wire Requirements

- Size and install all wiring in conformance with the requirements of national and local industrial safety regulations (NEC, VDE 0160, BSI, etc.)
- Use shielded wire for signal wire connections.
- Route all signal wiring away from high current lines such as AC lines.

Always run the signal wire in steel conduit. Never run the signal wire with non-signal wire.

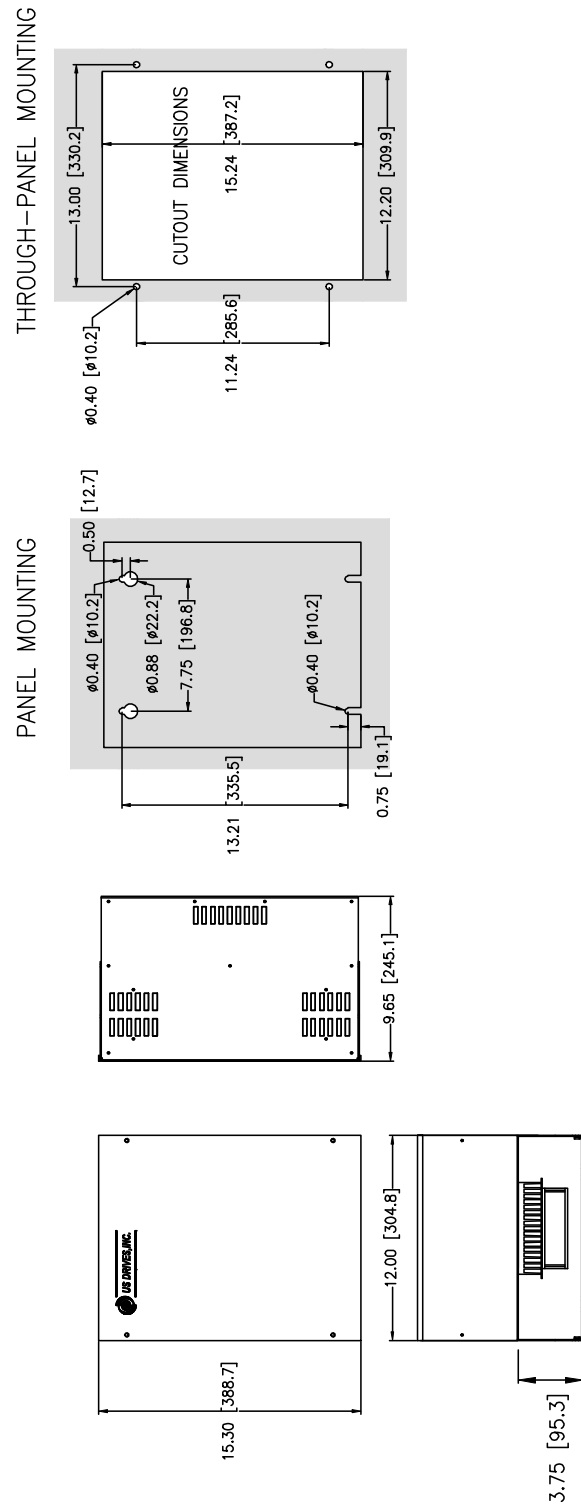

Approximate Weight: 35 Lbs. [16 Kgs]

Notes:

- Top and bottom endplates are removable to gain access inside the drive and to punch holes for conduits.
- Endplates must be removed from the drive before drilling and punching holes to avoid metal dust inside the drive enclosure. Failure to do so will cause damage to the drive.
- For through-panel mounting, customer is to seal for gap on all side of cutout. Provided by customer, aluminum angle 1" x 1" x 0.050" can be used to attach to all sides of drive to help seal and secure the drive.

Figure 2
AC Regen Mounting Information:
Size 1 (Nema Type 1)

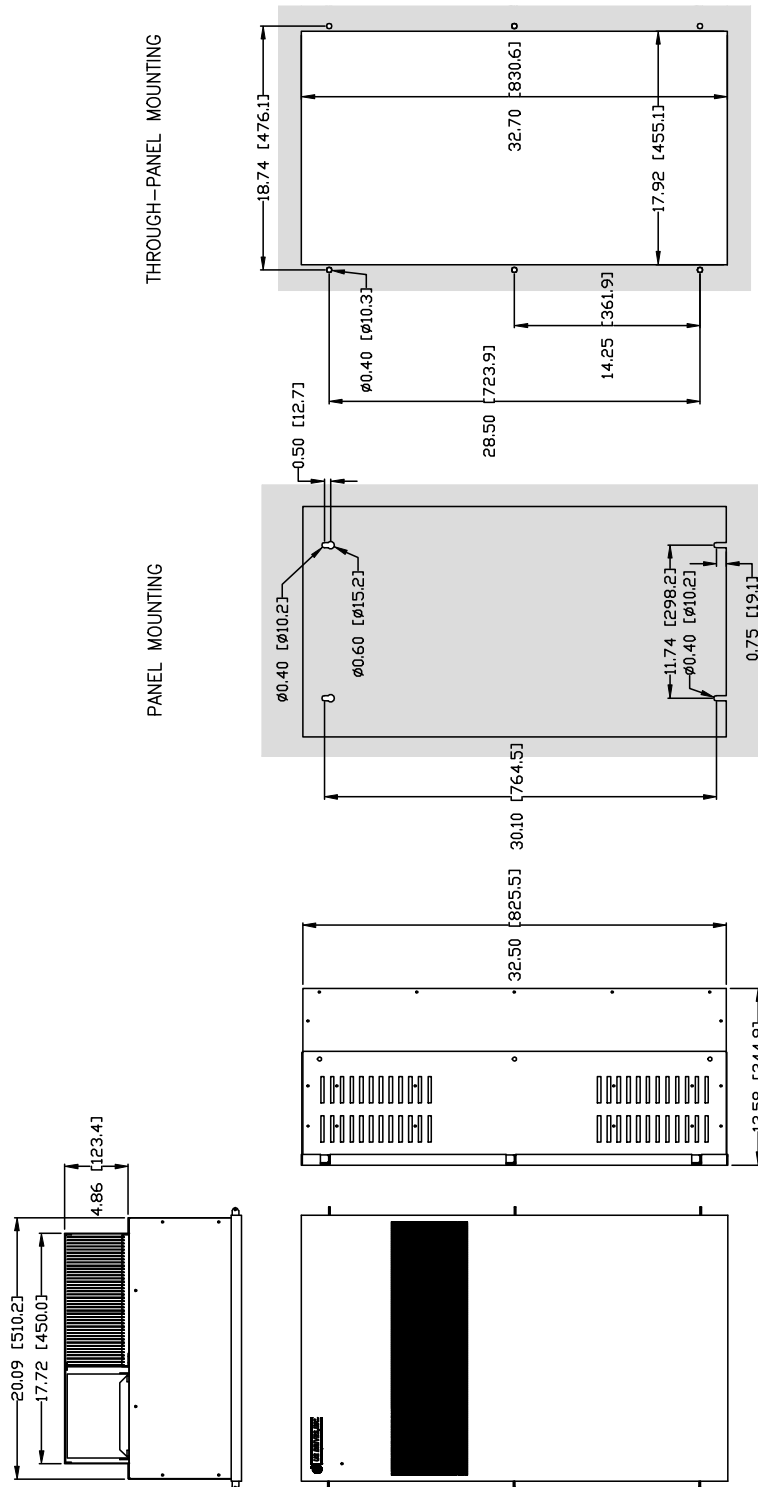

Approximate Weight: 150 Lbs. [68 Kgs]

Notes:

- Top and bottom endplates are removable to gain access inside the drive and to punch holes for conduits.
- Endplates must be removed from the drive before drilling and punching holes to avoid metal dust inside the drive enclosure. Failure to do so will cause damage to the drive.
- For through-panel mounting, customer is to seal for gap on all side of cutout. Provided by customer, aluminum angle 1" x 1" x 0.050" can be used to attach to all sides of drive to help seal and secure the drive.

Figure 2-2a
AC Regen Mounting Information:
Size 2 (Nema Type 1)

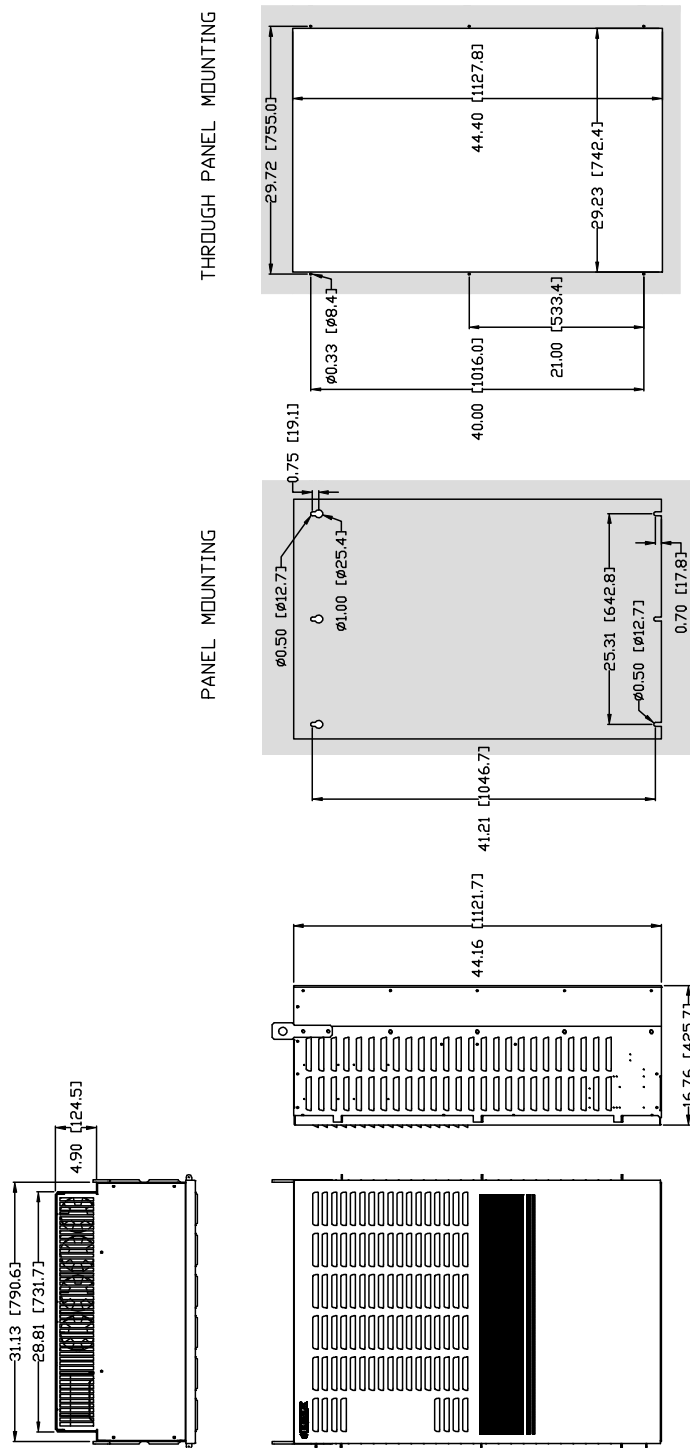

Approximate Weight: 450 Lbs. [204 Kgs]

Notes:

- Top and bottom endplates are removable to gain access inside the drive and to punch holes for conduits.
- Endplates must be removed from the drive before drilling and punching holes to avoid metal dust inside the drive enclosure. Failure to do so will cause damage to the drive.
- For through-panel mounting, customer is to seal for gap on all side of cutout. Provided by customer, aluminum angle 1" x 1" x 0.050" can be used to attach to all sides of drive to help seal and secure the drive.
- Size 3 enclosure can also be free-standing with optional floor stand kit from US Drives, Inc.

Figure 2-2b
AC Regen Mounting Information:
Size 3 (Nema Type 1)

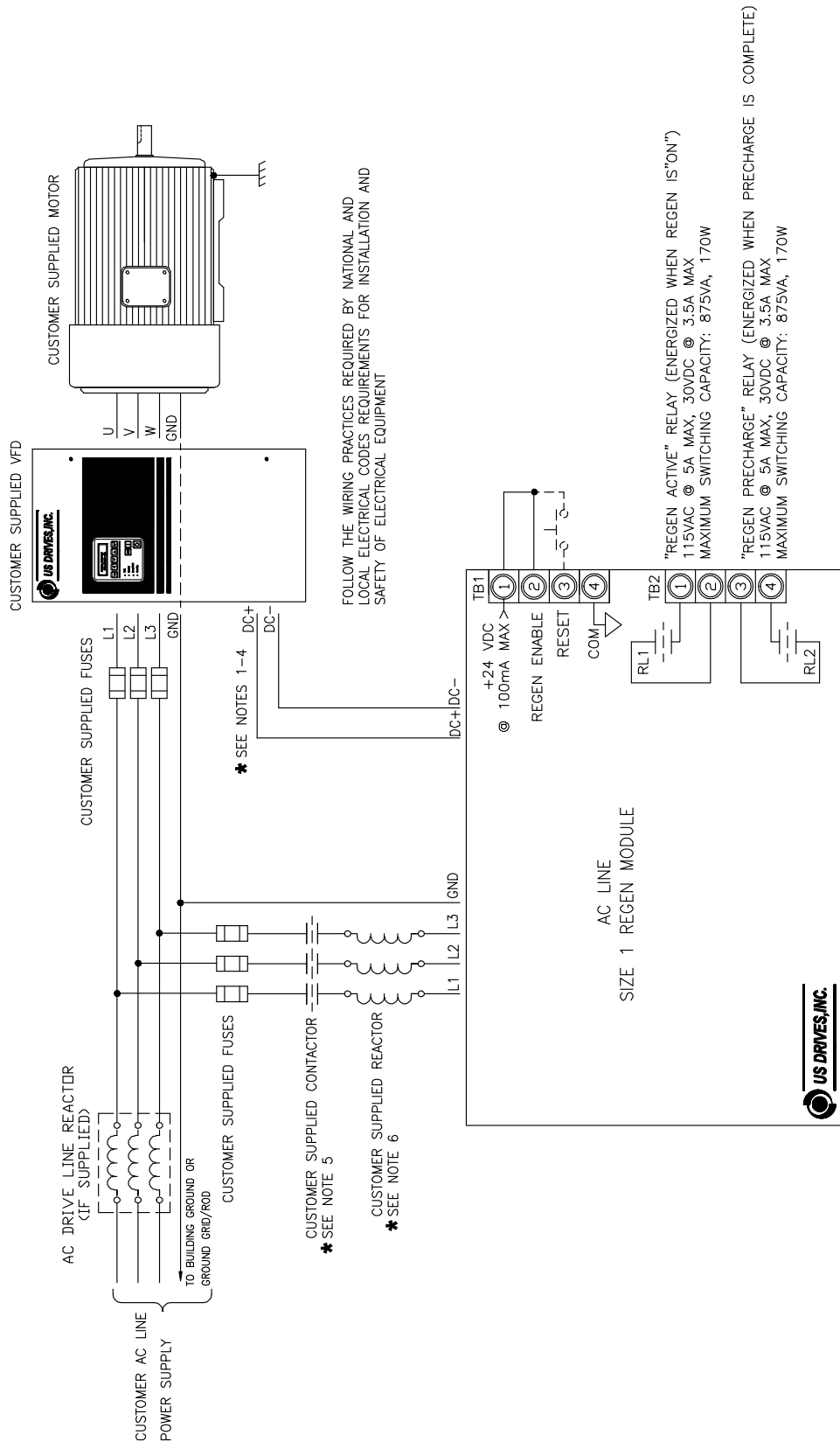

NOTES:

1. WIRE LENGTH MUST NOT EXCEED 10 FEET (3 METERS).
2. TWIST OR KEEP DC+ & DC- WIRES CLOSE TO EACH OTHER.
3. USE ONLY WITH FIXED-DC-BUS-VOLTAGE TYPE DRIVES.
4. THE DRIVE DC BUS TERMINALS MUST BE DIRECTLY ACROSS THE CAPACITOR BANK (NOT THROUGH THE DC BUS CHOKER). CHECK WITH DRIVE MANUFACTURER IF NOT SURE.
5. THE PRECHARGE CONTACTOR IS RATED FOR AC1 TYPE LOADS AND IS REQUIRED FOR ALL MODELS AND MUST BE ENERGIZED USING THE AC REGEN RELAY RL2. FOR A DETAILED PRINT, CONTACT THE FACTORY. PLEASE MAKE SURE THE CONTACTOR COIL REQUIREMENTS DO NOT EXCEED RL2 RELAY PER ABOVE. IF THE COIL DATA EXCEEDS THE RATING OF THE REGEN BUILT-IN RELAY, AN INTERMEDIARY POWER RELAY MUST BE USED. ALSO USE A SURGE SUPPRESSOR FOR THE CONTACTOR COIL. FOR COMMON BUS APPLICATION WHERE MULTIPLE AC DRIVES ARE CONNECTED TOGETHER, PRECHARGE RESISTORS (250 OHMS, 225W, WIRE WOUND VITREOUS ENAMEL) ARE REQUIRED AND MUST BE CONNECTED AS SHOWN IN FIGURE 3-3b AND THE CONTACTOR MUST BE ENERGIZED USING THE AC REGEN RELAY RL2 (SAME AS FIGURE 3-3a).
6. THIS REACTOR IS RECOMMENDED AS A FILTER. IF A DRIVE REACTOR OR A DRIVE TRANSFORMER IS PRESENT THIS REACTOR MAY BE OMITTED. A 3% IMPEDANCE IS RECOMMENDED.

Figure 3
Size 1 (Only)
Recommended Power Wiring

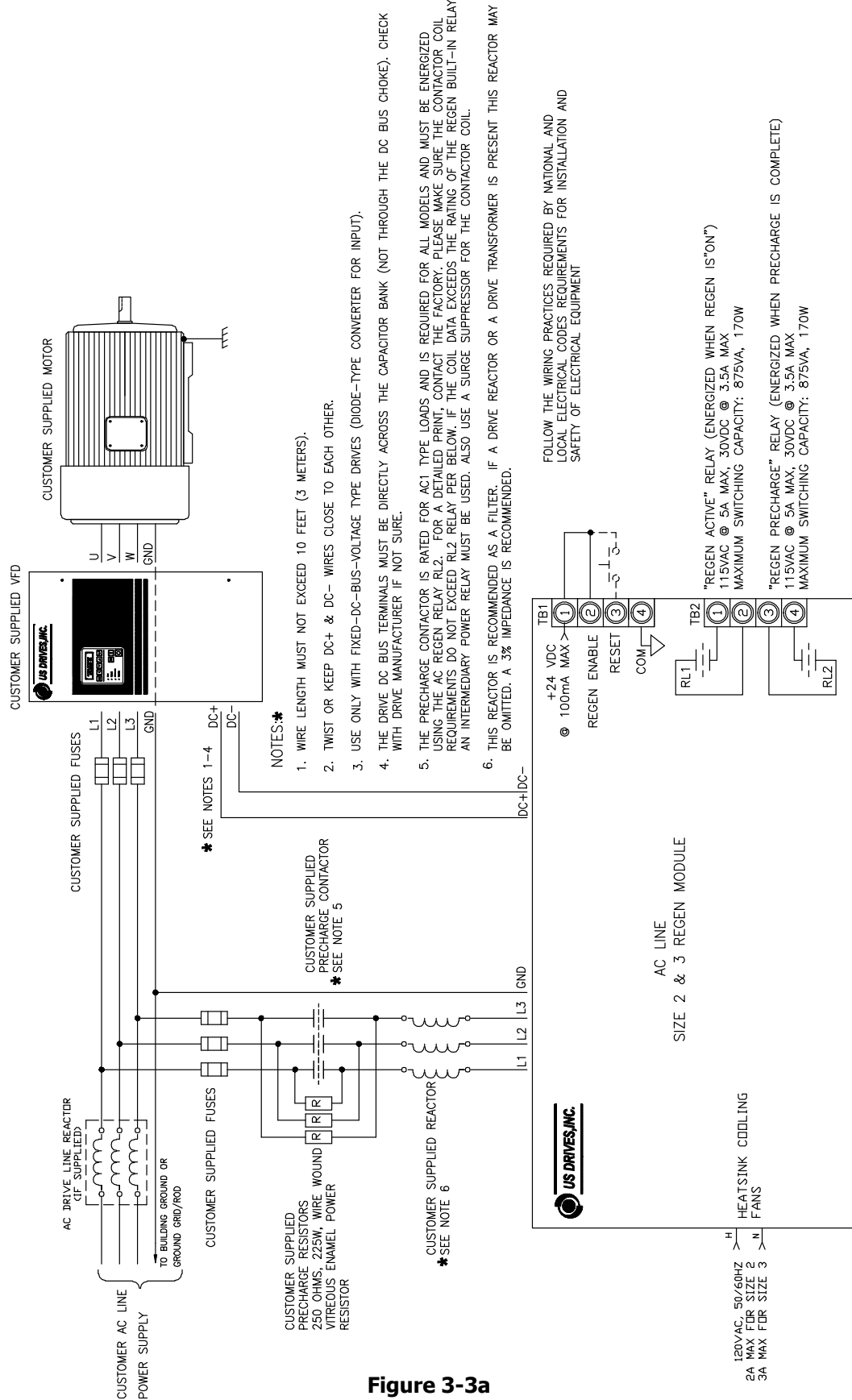
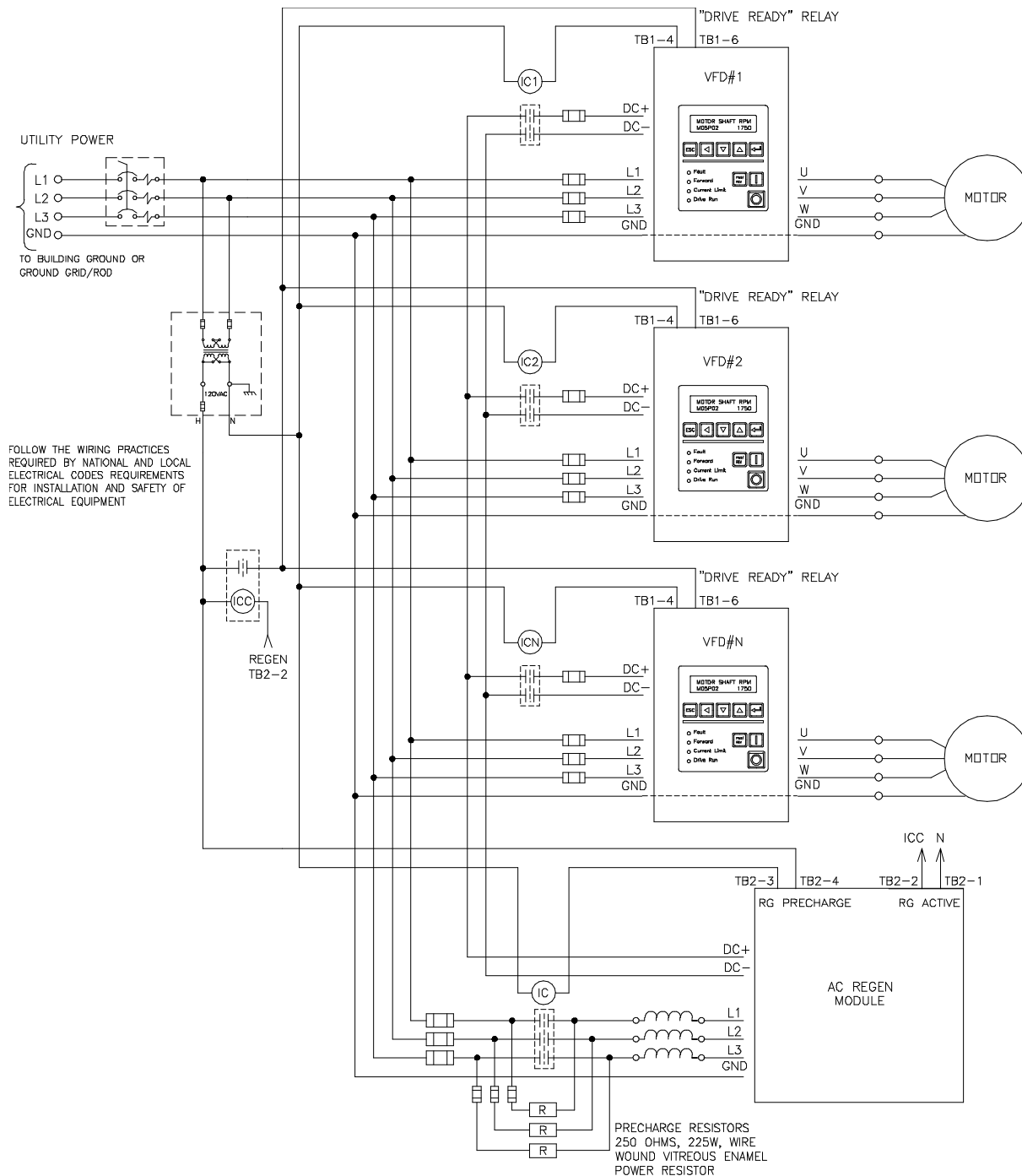

Figure 3-3a
Size 2 & 3
Recommended Power Wiring



AC REGEN NOTE:

- DC BUS WIRE LENGTH MUST NOT EXCEED 10 FEET (3 METERS) FROM CLOSEST AC DRIVE.
- TWIST OR KEEP DC+ & DC- WIRES CLOSE TO EACH OTHER.
- USE ONLY WITH FIXED-DC-BUS-VOLTAGE TYPE DRIVES (DIODE-TYPE CONVERTER FOR INPUT).
- THE DRIVE DC BUS TERMINALS MUST BE DIRECTLY ACROSS THE CAPACITOR BANK (NOT THROUGH THE DC BUS CHOKE). CHECK WITH DRIVE MANUFACTURER IF NOT SURE.
- A 3% AC LINE REACTOR IS RECOMMENDED AS A FILTER.
- ALL CONTACTORS SHOWN ARE AC CONTACTORS RATED FOR AC1 TYPE LOADS

BEFORE USING THE BUILT-IN RELAY TO PICK-UP ANY CONTACTOR YOU MUST CHECK THAT THE VA RATING OF THE CONTACTOR COIL DOES NOT EXCEED THE BUILT-IN RELAY USED IN THE AC REGEN OR THE AC DRIVES.

AC REGEN & PHOENIX AC DRIVES BUILT-IN RELAY DATA:
 RATED LOAD: 5A MAX @ 115VAC (INDUCTIVE LOAD)
 3.5A MAX @ 30VDC (INDUCTIVE LOAD)
 MAX SWITCHING CAPACITY: 875VA, 170W (INDUCTIVE LOAD)

Figure 3-3b
Size 1, 2 & 3
AC Regen Connection in a Common Bus System

Figure 4

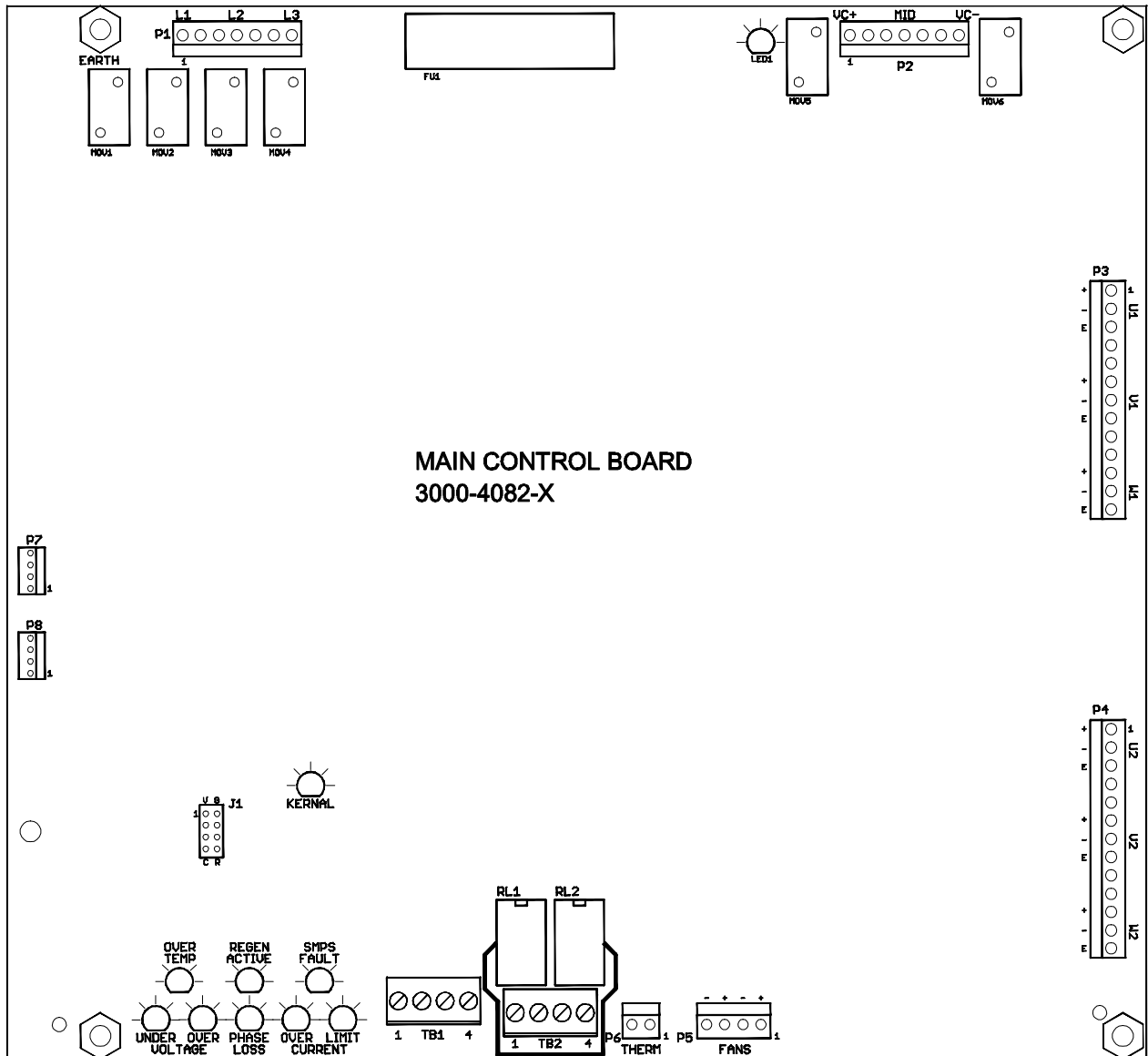

TB1-TB2 CONNECTION DATA:

MAXIMUM TORQUE: 5Lb-in [0.6 N-m]
 WIRE SIZE: AWG 26-16 [0.14-1.29 mm]

Main Control Board Terminal Block Layout

**Table 5
 Terminal Blocks Description for Control Board**

TERMINAL BLOCK	DESCRIPTION
TB1 TERM 1	24 Vdc @ 100mA Max.
TB1 TERM 2	Regen Enable (24 Vdc logic)
TB1 TERM 3	Regen Reset (24 Vdc logic)
TB1 TERM 4	Control circuit common
TB2 TERM 1 & 2	Normally open contact energized when Regen is "ON"
TB2 TERM 3 & 4	Normally open contact energized when "Regen Precharge" is complete

LED DESCRIPTIONS

Regen Active LED

This LED indicates when the *AC Regen* is active

Under-voltage LED

The under-voltage LED becomes lit when the DC bus voltage or AC line voltage drop below the minimum level. This fault is automatically cleared after the under-voltage condition disappears and the voltages stabilize.

Over-voltage LED

The over-voltage LED becomes lit when the DC bus voltage or AC line voltage exceed the maximum level. This fault is automatically cleared after the over-voltage condition disappears and the voltages stabilize.

Phase-loss LED

The phase-loss LED becomes lit when a phase-loss condition is detected or the AC line voltage drops below the minimum value. This fault is automatically cleared after the AC line voltage and phase stabilize.

Current Limit LED

This LED is lit whenever the DC current is over the rated level.

Over-temperature

The over-temperature LED becomes lit when the heatsink temperature exceeds the maximum level. The first fault is automatically cleared after the temperature drops to an acceptable level. If a second fault occurs within a minute, the fault is latched and clearing it requires a Regen reset.

Over-current LED

This fault is latched and clearing it requires a Regen reset after a 60 second timeout period.

SMPS LED

The SMPS LED becomes lit when the control supply drops below normal. The first fault is automatically cleared after the control power supply stabilizes. If a second fault occurs within a minute, the fault is latched and clearing it requires a Regen reset.

LEDs: at Start and Reset

- * While the *AC Regen* is detecting the line frequency all LEDs except the Regen Active LED will be lit.
- * If the *AC Regen* reset line is held active the drive will rapidly flash (every 100msec) all LEDs (except LED 1) to indicate that it is waiting for the reset line to be released.

LED 1

LED1 becomes lit when there is charge at the DC bus -Regen bus or drive bus. **To avoid a hazard of electric shock, after the input and control power is removed from the *AC REGEN* and the drive connected to it, wait five (5) minutes for bus capacitors to fully discharge.**

Kernel LED

The flashing Kernel LED is the microcontroller "heartbeat" indicating the CPU is operating properly.

-sizing the *AC REGEN*

The AC Regen module is very simply sized by the maximum desired braking horsepower. There is no need for complicated calculations to size the AC Regen Module. The rated continuous horsepower of the AC Regen is shown on table 1, 2 & 3, column # 5. The AC Regen module has a 150% overload for 1 minute. For example an RG-0400-0180-N1 is rated to regenerate 150 HP continuous with 225 HP for 1 minute. For a drive rated at 150 HP with a 150% overload, the correct AC Regen model for the drive is RG-0400-0180-N1.

A smaller AC Regen module can be used with a much larger AC Drive as long as the power regenerated does not exceed the rated horsepower of the AC Regen module and its overload ratings. Please note the input reactor of the AC Regen module must be sized per the rated horsepower of the AC Regen module.

Please note the AC Regen module is rated to regenerate the mechanical horsepower delivered by the AC motor regardless of the motor efficiency, the power factor and the number of poles.

Please do not use the average regenerated horsepower to size the AC Regen module. The chosen horsepower of the AC Regen module must be the horsepower at the highest operating speed.

It is best to match the AC Regen rated horsepower with the rated AC drive Horsepower when the drive is used at its capability.

AC REGEN POWER CIRCUIT TABLE

WARNING

To avoid an electric shock hazard, after the input and control power is removed from the drive and the AC Regen, wait five (5) minutes for Bus capacitors to fully discharge (DC Bus capacitors of the drive and the AC Regen). Verify that the voltage on the bus capacitors has discharged by measuring the DC bus voltage at the +DC & –DC terminals of the drive. The voltage must be zero.

Fuse Check:

Check all fuses. Do not replace any fuse before performing the following checks. Please note if an on-board fuse (soldered to the control board) is open, do not attempt to replace it. An open on-board fuse indicates a damaged board.

Visual Check:

Check all fuses, boards, wire harnesses, connectors, bus bars and enclosure walls for discoloration

Ohmic Check:

Check IGBT personality boards for the following:

- Burnt or discolored resistors R1, R2, & R3 (6 sets per Regen)
- Shorted D1 & D2 using meter set for diode check (6 sets per Regen).

These personality boards are either soldered or screwed on the IGBT’s (power transistors).

+ Lead	– Lead	Meter setting	Reading	
L1, L2, L3	VC+ @ PCB Connector P2	DIODE	0.3 - 0.5	
VC- @ PCB Connector P2	L1, L2, L3	DIODE	0.3 - 0.5	
DC+ @ User Connection	VC+ @ Connector P2	DIODE	0.3 - 0.5	
VC- @ PCB Connector P2	DC- @ User Connection	DIODE	0.3 - 0.5	
VC+ @ Connector P2	DC+ @ User Connection	DIODE	OL	
DC- @ User Connection	VC- @ PCB Connector P2	DIODE	OL	
VC+ @ PCB Connector P2	L1, L2, L3	DIODE	OL	
L1, L2, L3	VC- @ PCB Connector P2	DIODE	OL	
L1, L2, L3	CHASSIS GND	200k ohms	OL	
DC+ @ User Connection	CHASSIS GND	200k ohms	OL	
DC- @ User Connection	CHASSIS GND	200k ohms	OL	
VC+ @ PCB Connector P2	CHASSIS GND	200k ohms	OL	
VC- @ PCB Connector P2	CHASSIS GND	200k ohms	OL	

WARRANTY

US Drives, Inc. warrants the equipment described in this manual for thirty-six (36) months from the day of purchase, not to exceed forty (40) months from date of manufacture. US Drives, Inc. further warrants that such goods are free of defects in materials and workmanship.

If the goods fail to perform to US Drives, Inc. published specifications, then the Buyer must contact US Drives, Inc. to obtain a Return Material Authorization (RMA), prepare the goods for shipment and return the goods to US Drives, Inc. for repair or replacement at US Drives, Inc. Option. The buyer will bear all costs of transportation to and from US Drives, Inc. factory, risk of loss for goods not at US Drives, Inc. factory and any cost required to remove or prepare the goods for shipment to US Drives, Inc. factory and to reinstall equipment subsequent to repair.

In no event and under no circumstances shall the manufacturer be liable for: (a) damages and failures due to improper use or installation; (b) damage in shipment; (c) damage to abnormal conditions of temperature, dust, corrosives or failures due to operation above rated capacities, whether intentional or unintentional; (d) non-authorized service, repair, modification, transportation or installation. Nor shall the manufacturer ever be liable for consequential or incidental damages including any lost profits or lost savings.

There are no other warranties, expressed or implied, which extend beyond that described herein. The warranty set forth is exclusive and no other warranty, whether written or oral, is expressed or implied. US Drives, Inc. specifically disclaims the implied warranties of merchantability and fitness for a particular purpose.

The warranty is effective only if a written notification of any claim under this warranty is received by US Drives, Inc. at the address indicated below within thirty (30) days of recognition of defect by buyer.

US Drives, Inc. reserves the right to make changes and improvements in its goods without incurring any obligation to similarly alter goods previously purchased. US Drives, Inc. neither assumes nor authorizes any representative or any other person to assume for US Drives, Inc. any other liability in connection with the sale or any shipment of its goods.

US DRIVES, INC.
2221 Niagara Falls Boulevard
P.O. Box 281
Niagara Falls, NY 14304-0281
Tel: (716) 731-1606

Visit us at www.usdrivesinc.com

"THE HIGH HORSEPOWER DESIGN EXPERTS"

**US Drives, Inc.
2221 Niagara Falls Boulevard
P.O. Box 281
Niagara Falls, NY 14304-0281
Tel: (716) 731-1606
Visit us at www.usdrivesinc.com**

Products Designed and Manufactured
In The United States of America



RGIM10/24 Printed in U.S.A.