



“The High Horsepower Design Experts”



2024 Product Catalog

TABLE OF CONTENTS

<u>TITLE</u>	<u>PAGE</u>	<u>TITLE</u>	<u>PAGE</u>
<u>PHOENIX DS AC DRIVE</u>		<u>AC LINE REGENERATIVE MODULE</u>	
Phoenix DS Sensorless AC Vector Drive	DS1	AC Line Regen Module	RG1
Outstanding Features	DS2	Specifications and Features	RG2
Engineering Data	DS3	Table 1 - Class 200 AC Regen Models	RG3
Catalog Number Selection	DS5	Table 2 - Class 400 AC Regen Models	RG3
Dimensions / Drive Only	DS8	Table 3 - Class 500 AC Regen Models	RG4
Dimensions / Drive with AC Line Disconnect and Fuses	DS10	AC Regen Mounting Info - Size 1	RG5
Dimensions / Drive with Manual Contactor Bypass	DS12	AC Regen Mounting Info - Size 2	RG6
		AC Regen Mounting Info - Size 3	RG7
<u>PHOENIX ES AC DRIVE</u>		<u>REGENERATIVE DC COMMON BUS SUPPLY</u>	
Phoenix ES AC Vector Drive	ES1	Regenerative DC Common Bus Supply	RGB1
Outstanding Features	ES2	Specifications and Features	RGB2
Engineering Data	ES3	Table 1 - Class 200 Regenerative DC Common Bus Supply Models	RGB3
Catalog Number Selection	ES5	Table 2 - Class 400 Regenerative DC Common Bus Supply Models	RGB3
Dimensions / Drive Only	ES8	Table 3 - Class 500 Regenerative DC Common Bus Supply Models	RGB4
Dimensions / Drive with AC Line Disconnect and Fuses	ES10	AC Regen Mounting Info - Size 1	RGB5
Dimensions / Drive with Manual Contactor Bypass	ES12	AC Regen Mounting Info - Size 1A	RGB6
		AC Regen Mounting Info - Size 2	RGB7
		AC Regen Mounting Info - Size 3	RGB8
<u>PHOENIX DS CLEAN POWER DRIVE</u>			
Phoenix DS Clean Power (18 Pulse) AC Drive	CP1		
Outstanding Features	CP2		
Engineering Data	CP3		
Comparison of Drive Types	CP5		
Catalog Number Selection	CP7		
Dimensions, Nema 1 & Nema 12	CP10		
<u>PHOENIX OPTIONS</u>			
Option Descriptions	OPT1		
<u>COMMUNICATIONS</u>			
Communications Options	COM1		
Drivemaster	COM2		

Phoenix DS Sensorless AC Vector Drive



3 HP to 3500 HP

Standard Features:

- * Sensorless AC Vector Control for Precise Control of Motor Speed and Torque
- * Highest Starting Torque - Smart Power Start Maximizes Motor Torque Per Ampere
- * Continuous Automatic Tuning – Provides Optimal Performance Under All Conditions
- * No Need to Perform Auto-tune Routine or Disconnect the Motor from the Load or During Drive Start-Up
- * Operator Keypad with English Language Display – 2 Line, 32 Character. Easily Display any parameter including Motor Speed, Motor Current, Motor Voltage, Kw and Kwh. User Programmable Parameter Scaling and Formatting – Display “Real World” Values – GPM, CFM, PSI
- * Operator Keypad Includes Speed Increase/Decrease Keys, Start/Stop, Forward/Reverse and Fault Reset Keys also LED’s for “Current Limit”, “Fwd/Rev”, “Run” and “Fault.”
- * 50°C Ambient Temperature Rating (Nema 1 Enclosed Drives)
- * Tolerates High Input AC Line Voltages – 250/500/600 VAC +10% (240/480/575 VAC Input)
- * Ground Fault and Line to Line Short Circuit Protection
- * Programmable Speed Sensitive Motor Overload Protection to Comply with UL 508C Sections 43.3, 43.4 and 43.5
- * Power Loss Ride Through
- * High Performance PID Control Loop (Full Setpoint Control or Trim Control)
- * Sleep Mode PID
- * Pump Underload and Overload Protection and Load Recovery
- * Pump Backspin Control
- * Speed Increase / Decrease (MOP) Function



- * S Curve Accel/Decel Control
- * User Programmable Auto-Restart Function
- * Bi-Directional Flycatcher (Start Into a Rotating Motor) – No Inertia Limits
- * Built In Kw / Kwh Metering and Total Cost of Power Calculator
- * Programmable Time Based Function Generator and Programmable Threshold Detectors
- * Programmable time delay and logic functions (AND, OR, NOR) of bit parameters, digital inputs and outputs
- * Adding, subtracting, multiplying, dividing, ramping, limiting and/or filtering functions of parameters and analog inputs and outputs
- * Run Time and Power on Time Countdown Timers with Alarms plus Run Time and Power on Time Totalizers
- * Critical Speed Rejection, 3 Bands – Individually Programmable Bandwidth
- * Auto logging Fault History - Last 10 Faults Saved in Order of Occurrence
- * 8 Digital Inputs, 24 VDC (7 Programmable Inputs and 1 Fixed Stop/Enable Input)
- * 2 Programmable Digital Outputs – Two Form C Dry Contacts rated 5 Amps at 115VAC
- * 2 Programmable Analog Input Signals, -10 VDC to +10 VDC or 4 to 20 ma
- * 2 Programmable Analog Output Signals, -10 VDC to +10 VDC
- * DC Braking
- * Fixed or Variable Carrier Frequency
- * Much, Much, More..

THREE YEAR WARRANTY
MADE IN USA
DS1

The Phoenix series of AC Drives was designed with one goal in mind: To create the most reliable and rugged Digital AC Drive on the market today. Reading through our standard features, it's easy to see the engineering detail that has made the Phoenix an outstanding product. To prove our commitment, we back each drive with a Three Year Warranty.

OUTSTANDING FEATURES

High Voltage Ratings Line voltages in the United States are now averaging as high as 500VAC, in Canada that figure is 600VAC. Designing a product that doesn't take this fact into consideration will result in a product that will have power bridge failures or at best, nuisance overvoltage tripping. The Phoenix is rated to handle these new voltage averages with $\pm 10\%$ to spare!

Built In Radio Frequency Filter The RFI filter, that is standard in the Phoenix, reduces noise in the radio frequency band which may be generated by the drive. The R.F.I. filter has a secondary benefit of protecting the drive from high voltage transients which occur when attached to motors with long leads. Many drive manufacturers ignore these potential problems that can cause radio communications problems in a facility and weaken the integrity of the drive.

Input Line Suppression Metal oxide varistors are included on each unit to absorb line voltage transients, not only phase to phase, but also phase to ground. Without these suppression devices the drive's power semiconductors are exposed to high potential voltages.

Short Circuit Protection If any of the output phases are shorted together (motor stator failure) or if an output phase shorts to ground, the Phoenix will safely shut down protecting itself until the short is cleared. These types of conditions often occur during installation when a power lead is nicked and shorts to conduit.

Smart Power Start We have developed a unique starting feature in the Phoenix, which produces a higher starting torque in the motor, then that achieved by line starting. By independently finding the right voltage and frequency to apply to the motor, the Phoenix creates more starting torque than most Vector controlled drives! This is essential with loads that require high starting torque and high inertia loads.

50°C Ambient Temperature We know there are many places in North America where the ambient temperature can be very high during the summer months. Many products coming from overseas, however, have lowered their cost by providing a product that can only handle an ambient temperature of 104°F(40°C) in an enclosure. The Phoenix has been designed to handle the heat with a rating of 122°F(50°C) in a Nema type 1 enclosure.

Additional Standard Features:

- * Keypad with Configurable Display
- * Motor Overload Protection - Meets NEC 430
- * Coast to Rest or Ramp Stop
- * Isolated Control Circuitry
- * Non-Volatile Parameter Storage
- * User Security Code
- * Programmable Auto Restart
- * S Curve Accel / Decel

- * Eight Preset Speeds
- * Eight Accel / Decel Rates
- * Two Timers with Alarms for Customer Use
- * Two Threshold Detectors for Customer Use
- * Setpoint Control with PID
- * DC Injection Braking
- * Critical Speed Rejection
- * Kw / Kwh Metering

ENGINEERING DATA

Electrical Specifications:

Rated Input Voltage:	200-250Vac, 380-500Vac, 500-600Vac -15% of minimum, +10% of maximum.
Frequency Tolerance:	45-65 Hz
Number of Phases:	3
Displacement Power Factor:	.95 or greater
Efficiency:	97% or greater at rated current
Max. Short Circuit Current Rating:	200,000A rms symmetrical, 600 volts (when used with AC input line fuses specified in tables 1-1 to 1-3 of the Instruction Manual).

Control Specifications:

Control Method:	Sine coded PWM with programmable carrier. Space Vector control.
Output Voltage:	0 to rated voltage.
Output Frequency Range:	0 to 600 Hz.
Frequency accuracy:	Analog reference: 0.1% of max frequency. Digital reference: 0.01% of max frequency.
Frequency resolution:	Analog reference: 0.06Hz at 60Hz. Digital reference: 0.001Hz at 60Hz.
Accel/Decel:	0.1 to 3276 sec.
Drive overload:	At Constant Torque: 150% of drive rated output for 1 minute. At Variable Torque: 120% of drive rated output for 1 minute.
Inverse Time Overload:	Programmable motor overload protection to comply with N.E.C. Article 430.
Current limit:	Proactive current limit programmable in % of motor rated current.
Braking torque:	Approximately 20%.
Maximum connected motor:	2 times rated drive horsepower.

Environmental Specifications:

Ambient Temperature:	-10°C to 50°C (14°F to 122°F) Nema type 1 enclosed.
Storage Temperature:	-40°C to 70°C (-40°F to 158°F) Nema type 1 enclosed.
Altitude:	Sea level to 3300 Feet [1000m] without derating.
Humidity:	95% relative humidity non-condensing.
Vibration:	9.8m/sec ² (1.0G) peak.
Immunity:	IEEE C62.41-1991 Category B (Formerly known as IEEE 587) EN50082-2 (Generic Immunity Standard).
Input R.F.I. Filter:	Standard on all models.

Physical attributes:

Mounting:	Though hole or panel mount for size 0 to size 3 drives. Size 4 drives are free standing enclosure.
Nema Rating:	Type 1 (IP20) as standard, Type 12 (IP54) optional.
Construction:	Steel construction (reduces E.M.I.)

Protective Features:

- Programmable speed sensitive motor overload protection to comply with UL 508C sections 43.3, 43.4 and 43.5.
- Drive overload protection to protect inverter.
- Motor stall protection at acceleration /deceleration and constant speed operation.
- Peak output current monitoring to protect against line-to-line shorts and line-to-ground shorts.
- Heatsink over-temperature monitoring.
- AC line overvoltage protection.
- DC bus over-voltage protection.

- DC bus under-voltage protection.
- Programmable stall protection.
- Internal power supply monitoring.
- AC power loss detection.
- Critical speed rejection with programmable 3 points with bandwidth to avoid mechanical resonance.
- Flycatcher "catch a spinning motor".
- Password protection to prevent parameter changes by unauthorized personnel.
- 4 to 20ma reference loss detection.
- Programmable thresholds and more.

Control I/O:

- 8 Digital Inputs: 7 user programmable inputs and 1 dedicated input for "Stop", rated for 24Vdc logic control.
- 2 Digital Outputs: 2 programmable dry contacts rated 115Vac @ 5A; 30Vdc @ 3.5A.
- 2 analog inputs: -10 to +10V (10 bits) with 75K Ω input impedance or 4-20 mA @ 500 Ω - Programmable.
- 2 analog outputs: -10 to +10V (10 bits) @ 2 mA max with output impedance = 100 Ω . - Programmable.
- 1 voltage reference: +15Vdc reference @ 10 mA max.
- 24Vdc source: Use to power operator pushbuttons and US Drives, Inc. option boards: 24Vdc @ 80 mA max.

Standard Drives Features:

- New generation IGBT.
- Nema type 1 (IP20) as standard for all models.
- 50°C ambient with standard Nema type 1 (IP20) enclosure.
- High voltage ratings: 250Vac+10% , 500Vac+10% models and 600Vac+10% models
- Modbus RTU serial communications ready.
- Input line suppression: Metal oxide varistors for line-to-line and line-to-ground voltage surge protection.
- Built-in radio frequency filter.
- Nonvolatile parameter storage.
- All parameters are saved in EEPROM (nonvolatile).
- Auto logging fault history: ten last faults recorded in order of occurrence.
- Simple programming through the Real-time Operator module (R.O.M.) with all data entries and monitoring in engineering units with English descriptions.
- Set point Control P.I.D.
- Injection DC Braking with braking time calculated automatically by the drive.
- Critical speed rejection.
- Programmable auto restart.
- Parameter security code.
- User definable displays with programmable format and parameter scaling.
- 7 programmable digital inputs for custom setups.
- Metering: AC line voltage, motor current, motor voltage, DC Bus voltage, Kw, Kwh, running Kwh cost and more...
- 8 programmable digital preset speeds with user selectable acceleration and deceleration rates.
- M.O.P. function.
- Programmable PWM carrier frequency, fixed or variable.
- Programmable Time Based Function Generator and Programmable Threshold Detectors
- Run Time and Power on Time Countdown Timers with Alarms plus Run Time and Power on Time Totalizers
- Bi-directional auto-speed search (flycatcher) for starting into rotating loads.
- S-curve accel/decel control.
- Programmable time delay and logic functions (AND, OR, NOR) of bit parameters, digital inputs and outputs.
- Adding, subtracting, multiplying, dividing, ramping, limiting and/or filtering functions of parameters and analog inputs and outputs.
- Parameters can be displayed, routed to an analog/digital output or re-routed and used as an input parameter to control another function within the drive.
- User programmable functions and modes.
- Power loss ride through.
- Sleep mode PID.
- Pump underload and overload protection and load recovery.
- Pump backspin control.

CATALOG NUMBER EXPLANATION

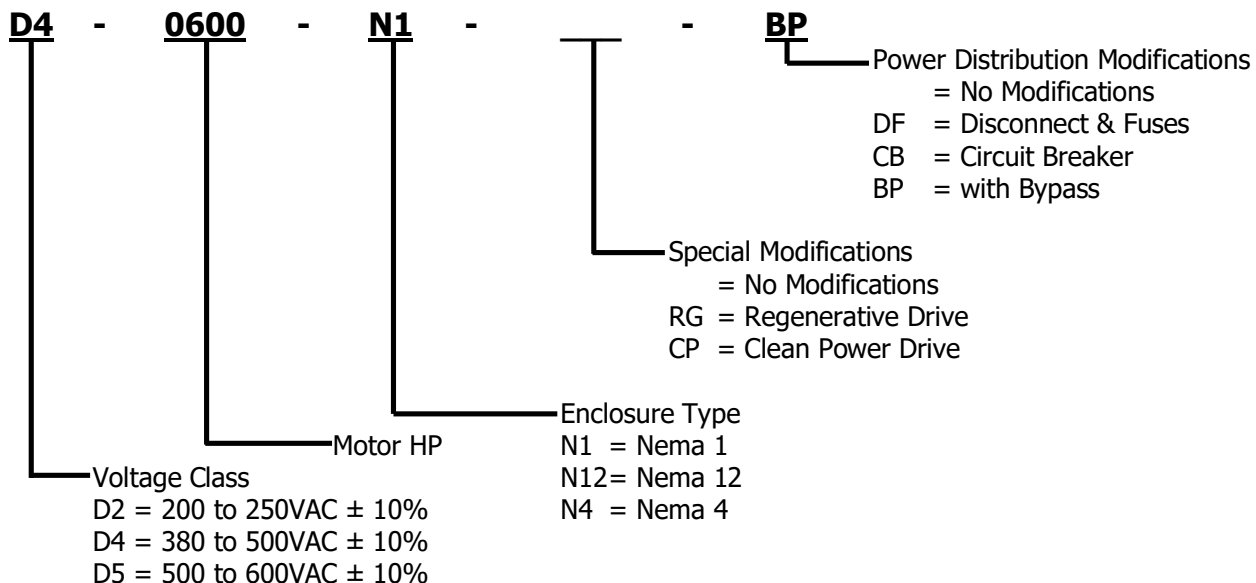

CATALOG NUMBER SELECTION / RATING TABLES

200-250VAC (-10% to +10%)												
Frame Designation	NEMA 1 (IP20) Catalog Number	Motor HP ¹		Output Current (Amps)		Output KVA ⁴		Input Current (Amps)		Input KVA ⁴		Maximum Recommended AC Line Fuses ⁵ (Amps)
		High Overload Capacity CT ²	Normal Overload Capacity VT ³	High Overload Capacity CT ²	Normal Overload Capacity VT ³	High Overload Capacity CT ²	Normal Overload Capacity VT ³	High Overload Capacity CT ²	Normal Overload Capacity VT ³	High Overload Capacity CT ²	Normal Overload Capacity VT ³	
SIZE 0	D2-0005-N1	3	5	10	16	4	7	12	19	5	8	35
	D2-0007-N1	5	7.5	16	22	7	9	19	25	8	10	40
	D2-0010-N1	7.5	10	22	28	9	12	25	33	10	14	50
	D2-0015-N1	10	15	28	42	12	17	25	36	10	15	60
	D2-0020-N1	15	20	42	54	17	22	36	50	15	21	70
	D2-0020CT-N1	20	-	54	-	22	-	50	-	21	-	70
SIZE 1	D2-0025-N1	20	25	54	68	22	28	50	61	21	25	90
	D2-0030-N1	25	30	68	85	28	35	61	79	25	33	100
	D2-0030CT-N1	30	-	80	-	33	-	74	-	31	-	100
SIZE 2	D2-0040-N1	30	40	80	104	33	43	74	96	31	40	150
	D2-0050-N1	40	50	104	130	43	54	96	120	40	50	200
	D2-0060-N1	50	60	130	163	54	68	120	155	50	64	250
	D2-0075-N1	60	75	154	192	60	80	140	186	58	77	300
	D2-0100-N1	75	100	192	248	80	103	186	230	77	96	300
	D2-0100CT-N1	100	-	248	-	103	-	230	-	96	-	300
SIZE 3	D2-0125VT-N1	-	125	-	312	-	130	-	290	-	121	6
	D2-0125CT-N1	125	-	312	-	130	-	290	-	121	-	6
	D2-0150VT-N1	-	150	-	360	-	150	-	335	-	139	6
	D2-0150CT-N1	150	-	360	-	150	-	335	-	139	-	6
	D2-0200VT-N1	-	200	-	480	-	200	-	446	-	186	6
	D2-0200CT-N1	200	-	480	-	200	-	446	-	186	-	6
	D2-250VT-N1	-	250	-	602	-	250	-	560	-	233	6
	D2-0250CT-N1	250	-	602	-	250	-	560	-	233	-	6

¹ Horsepower rating based on 230 VAC Motors.

² High Overload Capacity Drives (CT) produce 150% of Rated Drive Output Current for 1 minute.

³ Normal Overload Capacity Drive (VT) produce 120% of Rated Drive Output Current for 1 minute.

⁴ Output and Input KVA at nominal 240 VAC.

⁵ UL Class T, J and Semiconductor Fuses (preferred): Ferraz Shawmut A50Q, Busmann FWH.

⁶ Included as standard.

CATALOG NUMBER SELECTION / RATING TABLES

380-500VAC (-10% to +10%)												
Frame Designation	NEMA 1 (IP20) Catalog Number	Motor HP ¹		Output Current (Amps)		Output KVA ⁴		Input Current (Amps)		Input KVA ⁴		Maximum Recommended AC Line Fuses ⁵ (Amps)
		High Overload Capacity CT ²	Normal Overload Capacity VT ³	High Overload Capacity CT ²	Normal Overload Capacity VT ³	High Overload Capacity CT ²	Normal Overload Capacity VT ³	High Overload Capacity CT ²	Normal Overload Capacity VT ³	High Overload Capacity CT ²	Normal Overload Capacity VT ³	
SIZE 0	D4-0007-N1	5	7.5	8	11	7	9	10	13	8	11	25
	D4-0010-N1	7.5	10	11	14	9	12	13	17	11	14	30
	D4-0015-N1	10	15	14	21	12	17	17	25	14	21	40
	D4-0020-N1	15	20	21	27	17	22	25	33	21	27	50
	D4-0025-N1	20	25	27	34	22	28	26	31	22	26	50
	D4-0030-N1	25	30	34	43	28	36	31	38	26	32	60
	D4-0040-N1	30	40	40	52	33	43	36	48	30	40	70
D4-0040CT-N1	40	-	52	-	43	-	48	-	40	-	70	
SIZE 1	D4-0050-N1	40	50	52	66	43	55	48	56	40	47	90
	D4-0060-N1	50	60	65	82	54	68	56	72	47	60	100
	D4-0060CT-N1	60	-	77	-	64	-	67	-	56	-	100
SIZE 2	D4-0075-N1	60	75	77	97	64	81	67	83	56	69	125
	D4-0100-N1	75	100	96	124	80	103	86	110	71	91	175
	D4-0125-N1	100	125	124	156	103	130	110	139	91	116	200
	D4-0150-N1	125	150	156	180	130	150	139	163	116	136	250
	D4-0200-N1	150	200	180	240	150	200	167	223	139	186	350
D4-0200CT-N1	200	-	240	-	200	-	223	-	186	-	350	
SIZE 3	D4-250VT-N1	-	250	-	302	-	251	-	281	-	234	6
	D4-0250CT-N1	250	-	302	-	251	-	281	-	234	-	6
	D4-0300VT-N1	-	300	-	361	-	300	-	336	-	279	6
	D4-0300CT-N1	300	-	361	-	300	-	336	-	279	-	6
	D4-0350VT-N1	-	350	-	414	-	344	-	385	-	320	6
	D4-0350CT-N1	350	-	414	-	344	-	385	-	320	-	6
	D4-0400VT-N1	-	400	-	477	-	397	-	444	-	369	6
	D4-0400CT-N1	400	-	477	-	397	-	444	-	369	-	6
	D4-0450VT-N1	-	450	-	540	-	449	-	503	-	418	6
	D4-0450CT-N1	450	-	540	-	449	-	503	-	418	-	6
	D4-0500VT-N1	-	500	-	600	-	499	-	558	-	464	6
	D4-0500CT-N1	500	-	600	-	499	-	558	-	464	-	6
SIZE 4	D4-0600VT-N1	-	600	-	720	-	599	-	670	-	557	6
	D4-0600CT-N1	600	-	720	-	599	-	670	-	557	-	6
	D4-0700VT-N1	-	700	-	840	-	698	-	781	-	649	6
	D4-0700CT-N1	700	-	840	-	698	-	781	-	649	-	6
	D4-0800VT-N1	-	800	-	960	-	798	-	893	-	742	6
	D4-0800CT-N1	800	-	960	-	798	-	893	-	742	-	6
	D4-0900VT-N1	-	900	-	1080	-	898	-	1004	-	835	6
	D4-0900CT-N1	900	-	1080	-	898	-	1004	-	835	-	6
	D4-1000VT-N1	-	1000	-	1200	-	998	-	1116	-	928	6
	D4-1000CT-N1	1000	-	1200	-	998	-	1116	-	928	-	6
	D4-1250VT-N1	-	1250	-	1500	-	1247	-	1395	-	1160	6
	D4-1250CT-N1	1250	-	1500	-	1247	-	1395	-	1160	-	6
	D4-1500VT-N1	-	1500	-	1800	-	1496	-	1674	-	1392	6
	D4-1500CT-N1	1500	-	1800	-	1496	-	1674	-	1392	-	6
	D4-1750VT-N1	-	1750	-	2100	-	1746	-	1953	-	1624	6
	D4-1750CT-N1	1750	-	2100	-	1746	-	1953	-	1624	-	6
	D4-2000VT-N1	-	2000	-	2400	-	1995	-	2232	-	1856	6
D4-2000CT-N1	2000	-	2400	-	1995	-	2232	-	1856	-	6	
D4-2500VT-N1	-	2500	-	3000	-	2494	-	2790	-	2320	6	
D4-2500CT-N1	2500	-	3000	-	2494	-	2790	-	2320	-	6	

THIS VOLTAGE SERIES HAS A MAXIMUM HP RATING OF 3,000HP

¹ Horsepower rating based on 460 VAC Motors.

² High Overload Capacity Drives (CT) produce 150% of Rated Drive Output Current for 1 minute.

³ Normal Overload Capacity Drive (VT) produce 120% of Rated Drive Output Current for 1 minute.

⁴ Output and Input KVA at nominal 240 VAC.

⁵ UL Class T, J and Semiconductor Fuses (preferred): Ferraz Shawmut A50Q, Bussmann FWH.

⁶ Included as standard.

CATALOG NUMBER SELECTION / RATING TABLES

500-600VAC (-10% to +10%)													
Frame Designation	NEMA 1 (IP20) Catalog Number	Motor HP ¹		Output Current (Amps)		Output KVA ⁴		Input Current (Amps)		Input KVA ⁴		Maximum Recommended AC Line Fuses ⁵ (Amps)	
		High Overload Capacity CT ²	Normal Overload Capacity VT ³	High Overload Capacity CT ²	Normal Overload Capacity VT ³	High Overload Capacity CT ²	Normal Overload Capacity VT ³	High Overload Capacity CT ²	Normal Overload Capacity VT ³	High Overload Capacity CT ²	Normal Overload Capacity VT ³		
SIZE 0	D5-0007-N1	5	7.5	7	9	7	9	9	11	9	11	20	
	D5-0010-N1	7.5	10	9	12	9	12	11	13	11	13	25	
	D5-0015-N1	10	15	11	17	11	17	13	20	13	20	35	
	D5-0020-N1	15	20	17	22	17	22	20	25	20	25	40	
	D5-0025-N1	20	25	22	28	22	28	22	28	22	28	40	
	D5-0030-N1	25	30	27	34	27	34	27	34	27	34	50	
	D5-0040-N1	30	40	32	41	32	41	32	40	32	40	60	
D5-0040CT-N1	40	-	41	-	41	-	40	-	40	-	-	60	
SIZE 1	D5-0050-N1	40	50	41	52	41	52	40	48	40	48	80	
	D5-0060-N1	50	60	52	65	52	65	54	61	54	61	90	
	D5-0075-N1	60	75	62	78	62	78	58	72	58	72	100	
	D5-0075CT-N1	75	-	77	-	77	-	75	-	75	-	150	
SIZE 2	D5-0100-N1	75	100	77	99	77	99	75	96	75	96	150	
	D5-0125-N1	100	125	99	125	99	124	96	124	96	123	175	
	D5-0150-N1	125	150	125	157	124	156	124	154	123	153	200	
	D5-0200-N1	150	200	144	192	143	191	142	191	141	190	300	
	D5-0200CT-N1	200	-	192	-	191	-	191	-	190	-	300	
SIZE 3	D5-250VT-N1	-	250	-	242	-	241	-	240	-	239	350	
	D5-0250CT-N1	250	-	242	-	241	-	240	-	239	-	350	
	D5-0300VT-N1	-	300	-	289	-	288	-	286	-	285	400	
	D5-0300CT-N1	300	-	289	-	288	-	286	-	285	-	400	
	D5-0350VT-N1	-	350	-	336	-	335	-	333	-	331	500	
	D5-0350CT-N1	350	-	336	-	335	-	333	-	331	-	500	
	D5-0400VT-N1	-	400	-	382	-	380	-	378	-	377	600	
	D5-0400CT-N1	400	-	382	-	380	-	378	-	377	-	600	
	D5-0450VT-N1	-	450	-	432	-	430	-	428	-	426	700	
	D5-0450CT-N1	450	-	432	-	430	-	428	-	426	-	700	
	D5-0500VT-N1	-	500	-	472	-	470	-	467	-	465	700	
	D5-0500CT-N1	500	-	472	-	470	-	467	-	465	-	700	
	D5-0600VT-N1	-	600	-	576	-	574	-	570	-	568	800	
	D5-0600CT-N1	600	-	576	-	574	-	570	-	568	-	800	
	SIZE 4	D5-0700VT-N1	-	700	-	672	-	669	-	665	-	663	6
		D5-0700CT-N1	700	-	672	-	669	-	665	-	663	-	6
D5-0800VT-N1		-	800	-	768	-	765	-	760	-	757	6	
D5-0800CT-N1		800	-	768	-	765	-	760	-	757	-	6	
D5-0900VT-N1		-	900	-	864	-	860	-	855	-	852	6	
D5-0900CT-N1		900	-	864	-	860	-	855	-	852	-	6	
D5-1000VT-N1		-	1000	-	960	-	956	-	950	-	947	6	
D5-1000CT-N1		1000	-	960	-	956	-	950	-	947	-	6	
D5-1250VT-N1		-	1250	-	1200	-	1195	-	1188	-	1183	6	
D5-1250CT-N1		1250	-	1200	-	1195	-	1188	-	1183	-	6	
D5-1500VT-N1		-	1500	-	1440	-	1434	-	1426	-	1420	6	
D5-1500CT-N1		1500	-	1440	-	1434	-	1426	-	1420	-	6	
D5-1750VT-N1		-	1750	-	1680	-	1673	-	1663	-	1656	6	
D5-1750CT-N1		1750	-	1680	-	1673	-	1663	-	1656	-	6	
D5-2000VT-N1		-	2000	-	1920	-	1912	-	1901	-	1893	6	
D5-2000CT-N1		2000	-	1920	-	1912	-	1901	-	1893	-	6	
D5-2500VT-N1	-	2500	-	2400	-	2390	-	2376	-	2366	6		
D5-2500CT-N1	2500	-	2400	-	2390	-	2376	-	2366	-	6		

THIS VOLTAGE SERIES HAS A MAXIMUM HP RATING OF 3,000HP

¹ Horsepower rating based on 575 VAC Motors.

² High Overload Capacity Drives (CT) produce 150% of Rated Drive Output Current for 1 minute.

³ Normal Overload Capacity Drive (VT) produce 120% of Rated Drive Output Current for 1 minute.

⁴ Output and Input KVA at nominal 240 VAC.

⁵ UL Class T, CC, J and Semiconductor Fuses (preferred): Ferraz Shawmut A70Q, Bussmann FWP.

⁶ Included as standard.

Dimensions - Nema 1 Enclosed VFD Only

Input Voltage	Motor HP		Approximate Dimensions (HxWxD)	Figure	Mounting	Approximate Weight
	High Overload Capacity (CT)	Normal Overload Capacity (VT)				
200 - 250 VAC (208/230/240)	3 - 7.5	5 - 10	13.05" x 9.0" x 10.9"	1	Wall	30 Lbs.
	10 - 20	15 - 20	13.05" x 9.0" x 10.9"	1	Wall	30 Lbs.
	25 - 30	25 - 30	25" x 11.6" x 11.1"	2	Wall	75 Lbs.
	40 - 100	40 - 100	32.5" x 20.1" x 13.5"	3	Wall	180 Lbs.
	125 - 250	125 - 250	44.2" x 31.1" x 16.8"	4	Wall	500 Lbs.
	Above 250	Above 250	Consult Factory	-	-	-
380 - 500 VAC (380/400/415/480)	5 - 15	7.5 - 20	13.05" x 9.0" x 10.9"	1	Wall	30 Lbs.
	20 - 40	25 - 40	13.05" x 9.0" x 10.9"	1	Wall	30 Lbs.
	50 - 60	50 - 60	25" x 11.6" x 11.1"	2	Wall	75 Lbs.
	75 - 200	75 - 200	32.5" x 20.1" x 13.5"	3	Wall	180 Lbs.
	250 - 500	250 - 500	44.2" x 31.1" x 16.8"	4	Wall	500 Lbs.
	600 - 1000	600 - 1000	72" x 72" x 23.5"	6	Floor	1800 Lbs.
Above 1000	Above 1000	Consult Factory	-	-	-	
525 - 600 VAC (525/575/600)	5 - 15	7.5 - 20	13.05" x 9.0" x 10.9"	1	Wall	30 Lbs.
	20 - 40	25 - 40	13.05" x 9.0" x 10.9"	1	Wall	30 Lbs.
	50 - 75	50 - 75	25" x 11.6" x 11.1"	2	Wall	75 Lbs.
	100 - 200	100 - 200	32.5" x 20.1" x 13.5"	3	Wall	180 Lbs.
	250 - 600	250 - 600	44.2" x 31.1" x 16.8"	4	Wall	500 Lbs.
	700 - 1200	700 - 1200	72" x 72" x 23.5"	6	Floor	1800 Lbs.
Above 1200	Above 1200	Consult Factory	-	-	-	

Dimensions - Nema 12 Enclosed VFD Only

Input Voltage	Motor HP		Approximate Dimensions (HxWxD)	Figure	Mounting	Approximate Weight
	High Overload Capacity (CT)	Normal Overload Capacity (VT)				
200 - 250 VAC (208/230/240)	3 - 7.5	5 - 10	13.05" x 9.0" x 10.9"	1	Wall	35 Lbs.
	10 - 20	15 - 20	13.05" x 9.0" x 10.9"	1	Wall	35 Lbs.
	25 - 30	25 - 30	25" x 11.6" x 11.1"	2	Wall	80 Lbs.
	40 - 100	40 - 100	32.5" x 20.1" x 13.5"	3	Wall	185 Lbs.
	125 - 250	125 - 250	72" x 36" x 23.5"	5	Floor	870 Lbs.
	Above 250	Above 250	Consult Factory	-	-	-
380 - 500 VAC (380/400/415/480)	5 - 15	7.5 - 20	13.05" x 9.0" x 10.9"	1	Wall	35 Lbs.
	20 - 40	25 - 40	13.05" x 9.0" x 10.9"	1	Wall	35 Lbs.
	50 - 60	50 - 60	25" x 11.6" x 11.1"	2	Wall	80 Lbs.
	75 - 200	75 - 200	32.5" x 20.1" x 13.5"	3	Wall	185 Lbs.
	250 - 500	250 - 500	72" x 36" x 23.5"	5	Floor	870 Lbs.
	600 - 1000	600 - 1000	72" x 72" x 23.5"	6	Floor	1800 Lbs.
Above 1000	Above 1000	Consult Factory	-	-	-	
525 - 600 VAC (525/575/600)	5 - 15	7.5 - 20	13.05" x 9.0" x 10.9"	1	Wall	35 Lbs.
	20 - 40	25 - 40	13.05" x 9.0" x 10.9"	1	Wall	35 Lbs.
	50 - 75	50 - 75	25" x 11.6" x 11.1"	2	Wall	80 Lbs.
	100 - 200	100 - 200	32.5" x 20.1" x 13.5"	3	Wall	185 Lbs.
	250 - 600	250 - 600	72" x 36" x 23.5"	5	Floor	870 Lbs.
	700 - 1200	700 - 1200	72" x 72" x 23.5"	6	Floor	1800 Lbs.
Above 1200	Above 1200	Consult Factory	-	-	-	

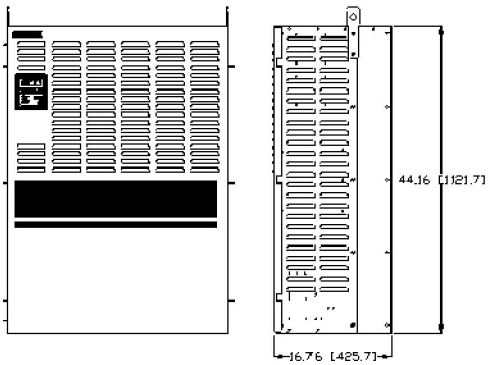
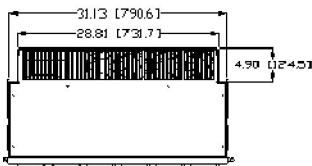
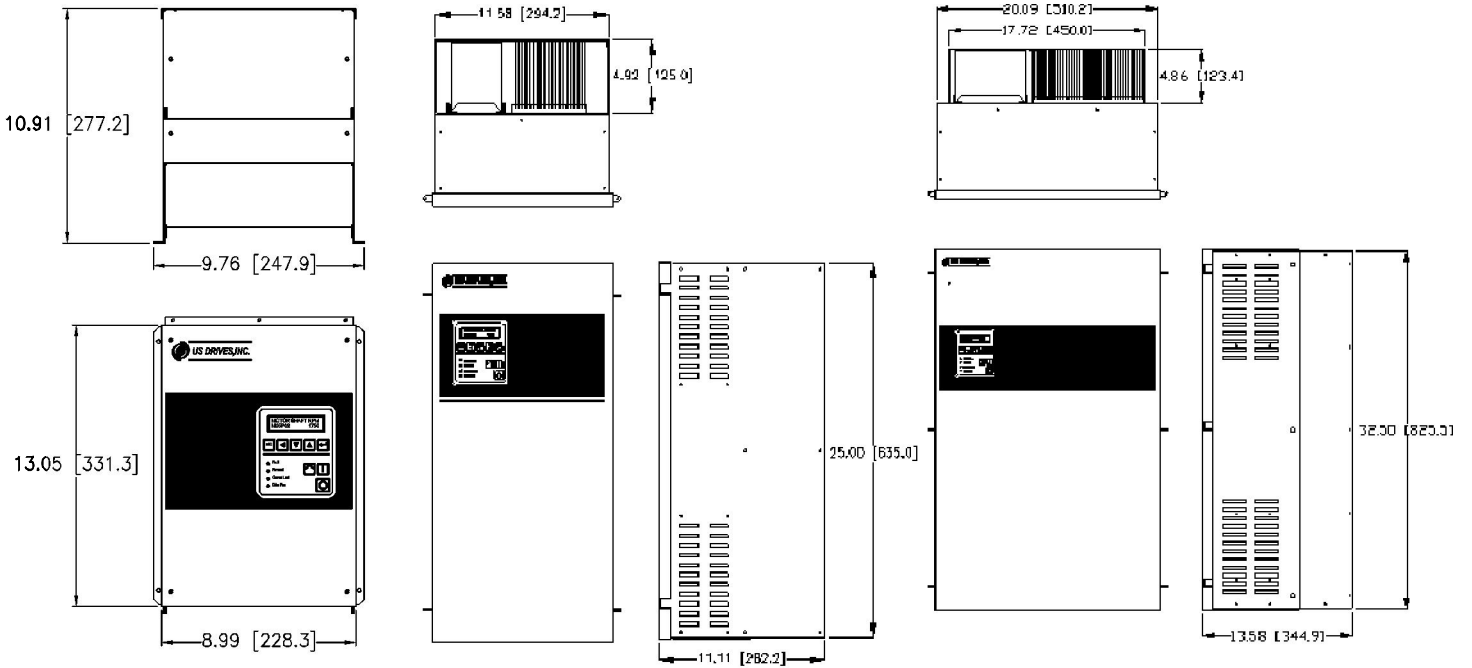

Figure 4

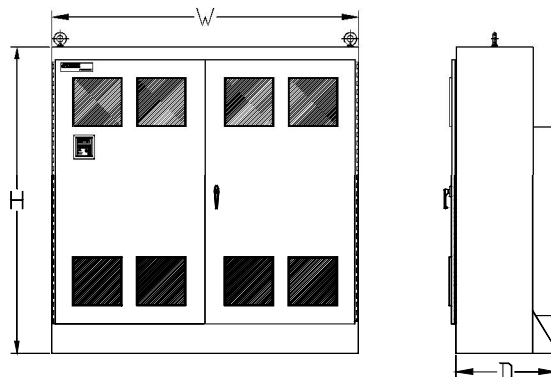
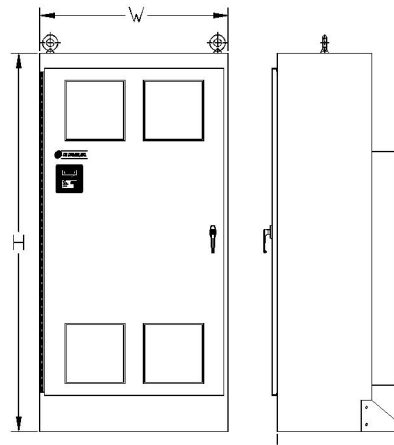

Figure 6

Dimensions - Nema 1 Enclosed VFD with Input Disconnect & Fuses

Input Voltage	Motor HP		Approximate Dimensions (HxWxD)	Figure	Mounting	Approximate Weight
	High Overload Capacity (CT)	Normal Overload Capacity (VT)				
200 - 250 VAC (208/230/240)	3 - 7.5	5 - 10	20.74" x 9.0" x 10.9"	7	Wall	46 Lbs.
	10 - 20	15 - 20	20.74" x 9.0" x 10.9"	7	Wall	46 Lbs.
	25 - 30	25 - 30	25" x 11.6" x 11.1"	8	Wall	85 Lbs.
	40 - 100	40 - 100	32.5" x 20.1" x 13.5"	9	Wall	190 Lbs.
	125 - 250	125 - 250	72" x 31.5" x 18"	11	Wall	650 Lbs.
	Above 250	Above 250	Consult Factory	-	-	-
380 - 500 VAC (380/400/415/480)	5 - 15	7.5 - 20	20.74" x 9.0" x 10.9"	7	Wall	46 Lbs.
	20 - 40	25 - 40	20.74" x 9.0" x 10.9"	7	Wall	46 Lbs.
	50 - 60	50 - 60	25" x 11.6" x 11.1"	8	Wall	85 Lbs.
	75 - 200	75 - 200	32.5" x 20.1" x 13.5"	9	Wall	190 Lbs.
	250 - 500	250 - 500	72" x 31.5" x 18"	11	Wall	650 Lbs.
	600 - 1000	600 - 1000	90" x 72" x 25.5"	12	Floor	1950 Lbs.
Above 1000	Above 1000	Consult Factory	-	-	-	
525 - 600 VAC (525/575/600)	5 - 15	7.5 - 20	20.74" x 9.0" x 10.9"	7	Wall	46 Lbs.
	20 - 40	25 - 40	20.74" x 9.0" x 10.9"	7	Wall	46 Lbs.
	50 - 75	50 - 75	25" x 11.6" x 11.1"	8	Wall	85 Lbs.
	100 - 200	100 - 200	32.5" x 20.1" x 13.5"	9	Wall	190 Lbs.
	250 - 600	250 - 600	72" x 31.1" x 18"	11	Wall	650 Lbs.
	700 - 1200	700 - 1200	90" x 72" x 25.5"	12	Floor	1950 Lbs.
Above 1200	Above 1200	Consult Factory	-	-	-	

Dimensions - Nema 12 Enclosed VFD with Input Disconnect & Fuses

Input Voltage	Motor HP		Approximate Dimensions (HxWxD)	Figure	Mounting	Approximate Weight
	High Overload Capacity (CT)	Normal Overload Capacity (VT)				
200 - 250 VAC (208/230/240)	3 - 7.5	5 - 10	20.74" x 9.0" x 10.9"	7	Wall	50 Lbs.
	10 - 20	15 - 20	20.74" x 9.0" x 10.9"	7	Wall	50 Lbs.
	25 - 30	25 - 30	25" x 11.6" x 11.1"	8	Wall	90 Lbs.
	40 - 100	40 - 100	32.5" x 20.1" x 13.5"	9	Wall	190 Lbs.
	125 - 250	125 - 250	72" x 36" x 23.5"	10	Floor	900 Lbs.
	Above 250	Above 250	Consult Factory	-	-	-
380 - 500 VAC (380/400/415/480)	5 - 15	7.5 - 20	20.74" x 9.0" x 10.9"	7	Wall	50 Lbs.
	20 - 40	25 - 40	20.74" x 9.0" x 10.9"	7	Wall	50 Lbs.
	50 - 60	50 - 60	25" x 11.6" x 11.1"	8	Wall	90 Lbs.
	75 - 200	75 - 200	32.5" x 20.1" x 13.5"	9	Wall	190 Lbs.
	250 - 500	250 - 500	72" x 36" x 23.5"	10	Floor	900 Lbs.
	600 - 1000	600 - 1000	90" x 72" x 25.5"	12	Floor	1950 Lbs.
Above 1000	Above 1000	Consult Factory	-	-	-	
525 - 600 VAC (525/575/600)	5 - 15	7.5 - 20	20.74" x 9.0" x 10.9"	7	Wall	50 Lbs.
	20 - 40	25 - 40	20.74" x 9.0" x 10.9"	7	Wall	50 Lbs.
	50 - 75	50 - 75	25" x 11.6" x 11.1"	8	Wall	90 Lbs.
	100 - 200	100 - 200	32.5" x 20.1" x 13.5"	9	Wall	190 Lbs.
	250 - 600	250 - 600	72" x 36" x 23.5"	10	Floor	900 Lbs.
	700 - 1200	700 - 1200	90" x 72" x 25.5"	12	Floor	1950 Lbs.
Above 1200	Above 1200	Consult Factory	-	-	-	

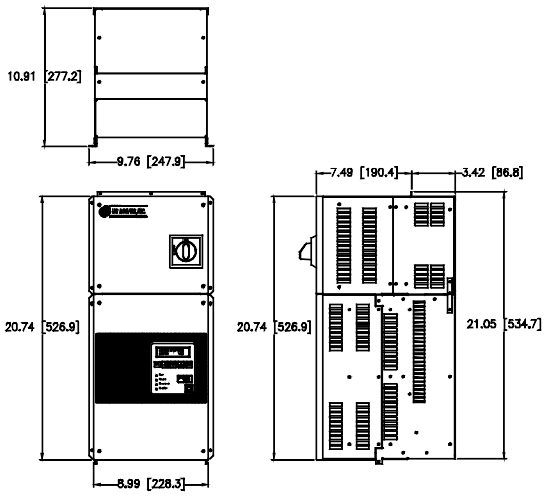

Figure 7

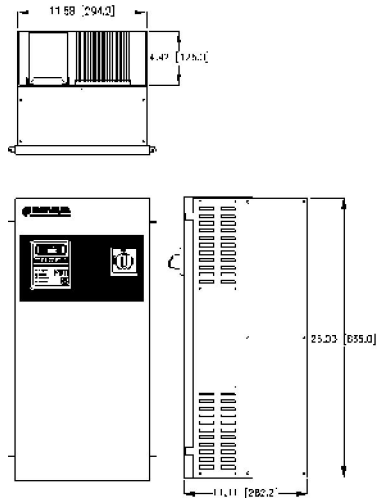

Figure 8

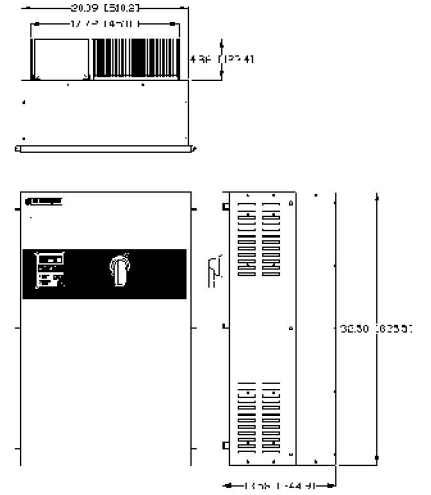

Figure 9

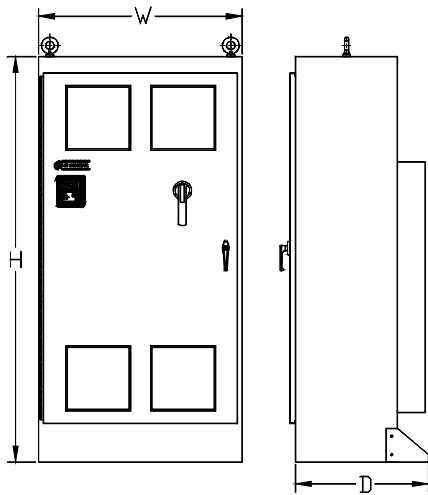

Figure 10

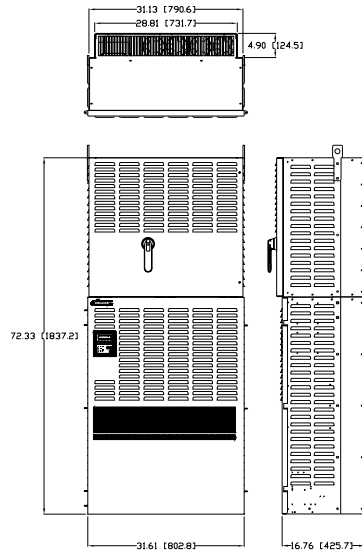

Figure 11

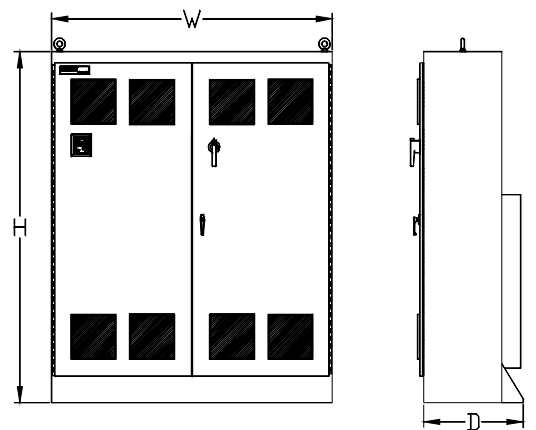

Figure 12

Dimensions - Nema 1 Enclosed VFD with Manual Contactor Bypass

Input Voltage	Motor HP		Approximate Dimensions (HxWxD)	Figure	Mounting	Approximate Weight
	High Overload Capacity (CT)	Normal Overload Capacity (VT)				
200 - 250 VAC (208/230/240)	3 - 7.5	5 - 10	34.02" x 9.0" x 10.9"	13	Wall	79 Lbs.
	10 - 20	15 - 20	34.02" x 9.0" x 10.9"	13	Wall	79 Lbs.
	25 - 30	25 - 30	38.4" x 11.6" x 11.1"	14	Wall	120 Lbs.
	40 - 100	40 - 100	65" x 20.1" x 13.5"	15	Wall	250 Lbs.
	125 - 200	125 - 200	72" x 72" x 23.5"	17	Floor	1400 Lbs.
	250	250	72" x 72" x 23.5"	17	Floor	1700 Lbs.
	Above 250	Above 250	Consult Factory	-	-	-
380 - 500 VAC (380/400/415/480)	5 - 15	7.5 - 20	34.02" x 9.0" x 10.9"	13	Wall	79 Lbs.
	20 - 40	25 - 40	34.02" x 9.0" x 10.9"	13	Wall	79 Lbs.
	50 - 60	50 - 60	38.4" x 11.6" x 11.1"	14	Wall	120 Lbs.
	75 - 200	75 - 200	65" x 20.1" x 13.5"	15	Wall	250 Lbs.
	250 - 400	250 - 400	72" x 72" x 23.5"	17	Floor	1400 Lbs.
	450 - 500	450 - 500	72" x 72" x 23.5"	17	Floor	1700 Lbs.
	600 - 1000	600 - 1000	Consult Factory	-	-	-
	Above 1000	Above 1000	Consult Factory	-	-	-
525 - 600 VAC (525/575/600)	5 - 15	7.5 - 20	24" x 24" x 14.2"	16	Wall	85 Lbs.
	20 - 40	25 - 40	24" x 30" x 14.2"	16	Wall	95 Lbs.
	50 - 75	50 - 75	38.4" x 11.6" x 11.1"	14	Wall	120 Lbs.
	100 - 200	100 - 200	65" x 20.1" x 13.5"	15	Wall	250 Lbs.
	250 - 400	250 - 400	72" x 72" x 23.5"	17	Floor	1400 Lbs.
	450 - 600	450 - 600	72" x 72" x 23.5"	17	Floor	1700 Lbs.
	700 - 1200	700 - 1200	Consult Factory	-	-	-
	Above 1200	Above 1200	Consult Factory	-	-	-

Dimensions - Nema 12 Enclosed VFD with Manual Contactor Bypass

Input Voltage	Motor HP		Approximate Dimensions (HxWxD)	Figure	Mounting	Approximate Weight
	High Overload Capacity (CT)	Normal Overload Capacity (VT)				
200 - 250 VAC (208/230/240)	3 - 7.5	5 - 10	34.02" x 9.0" x 10.9"	13	Wall	85 Lbs.
	10 - 20	15 - 20	34.02" x 9.0" x 10.9"	13	Wall	85 Lbs.
	25 - 30	25 - 30	38.4" x 11.6" x 11.1"	14	Wall	125 Lbs.
	40 - 100	40 - 100	65" x 20.1" x 13.5"	15	Wall	255 Lbs.
	125 - 200	125 - 200	72" x 72" x 23.5"	17	Floor	1450 Lbs.
	250	250	72" x 72" x 23.5"	17	Floor	1750 Lbs.
	Above 250	Above 250	Consult Factory	-	-	-
380 - 500 VAC (380/400/415/480)	5 - 15	7.5 - 20	34.02" x 9.0" x 10.9"	13	Wall	85 Lbs.
	20 - 40	25 - 40	34.02" x 9.0" x 10.9"	13	Wall	85 Lbs.
	50 - 60	50 - 60	38.4" x 11.6" x 11.1"	14	Wall	125 Lbs.
	75 - 200	75 - 200	65" x 20.1" x 13.5"	15	Wall	255 Lbs.
	250 - 400	250 - 400	72" x 72" x 23.5"	17	Floor	1450 Lbs.
	450 - 500	450 - 500	72" x 72" x 23.5"	17	Floor	1750 Lbs.
	600 - 1000	600 - 1000	Consult Factory	-	-	-
	Above 1000	Above 1000	Consult Factory	-	-	-
525 - 600 VAC (525/575/600)	5 - 15	7.5 - 20	24" x 24" x 14.2"	16	Wall	85 Lbs.
	20 - 40	25 - 40	24" x 30" x 14.2"	16	Wall	95 Lbs.
	50 - 75	50 - 75	38.4" x 11.6" x 11.1"	14	Wall	125 Lbs.
	100 - 200	100 - 200	65" x 20.1" x 13.5"	15	Wall	255 Lbs.
	250 - 400	250 - 400	72" x 72" x 23.5"	17	Floor	1450 Lbs.
	450 - 600	450 - 600	72" x 72" x 23.5"	17	Floor	1750 Lbs.
	700 - 1200	700 - 1200	Consult Factory	-	-	-
	Above 1200	Above 1200	Consult Factory	-	-	-

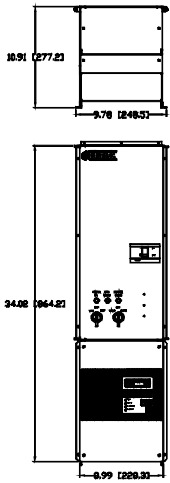

Figure 13

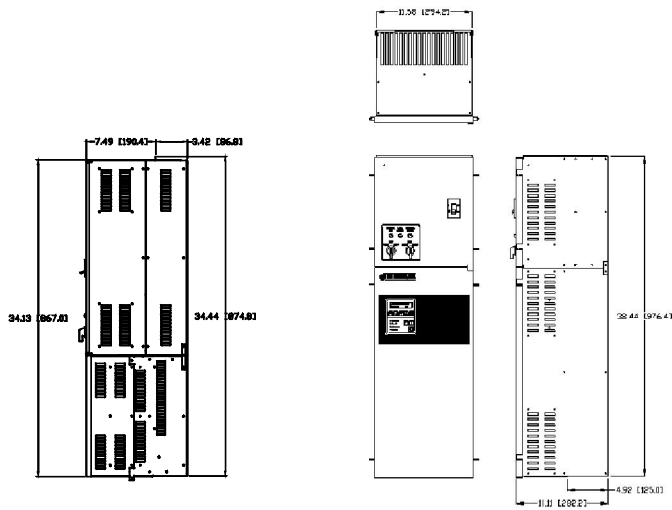

Figure 14

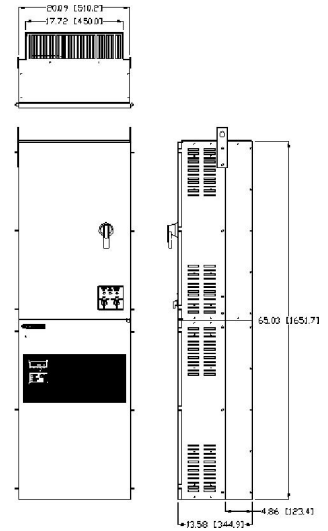

Figure 15

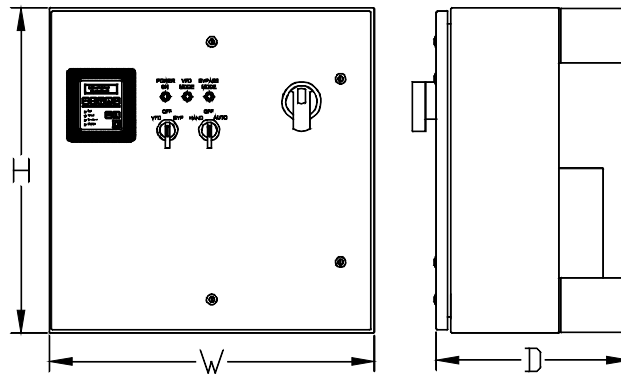

Figure 16

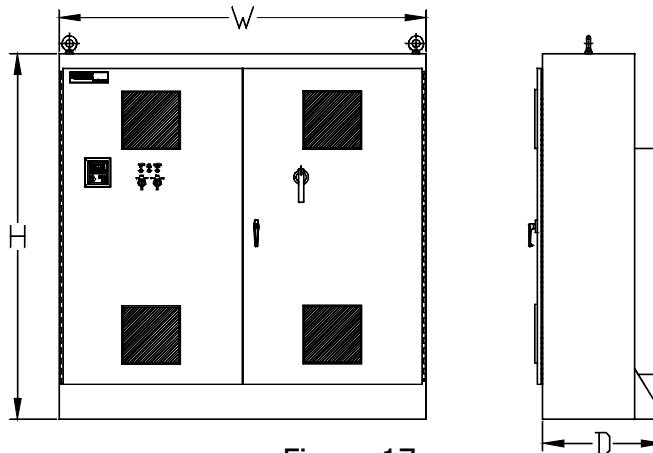

Figure 17

Phoenix ES AC Vector Drive



3 HP to 3500 HP

Standard Features:

- * *Open Loop AC Vector Control*
 - 100 to 1 Speed Range, 0.1% Speed Regulation - Open Loop Control (Standard)
- * *Closed Loop AC Vector Control*
 - 1000 to 1 Speed Range, 0.01% Speed Regulation - Closed Loop Control (with Encoder Feedback Card)
 - Speed Control, Torque Control, Speed Control with Torque Limit, Torque Control with Speed Limit
 - Full Torque at Zero Speed – Hold Position / Hold Zero Speed
 - Rigid and non-rigid position control including orientation
 - Permanent Magnet Motor Control
- * *No Need to Perform Auto-tune Routine or Disconnect the Motor from the Load or During Drive Start-Up*
- * *Operator Keypad with English Language Display – 2 Line, 32 Character. Easily Display any parameter including Motor Speed, Motor Current, Motor Voltage, Kw and kWh. User Programmable Parameter Scaling and Formatting – Display "Real World" Values – GPM, CFM, PSI*
- * *Operator Keypad Includes Speed Increase/Decrease Keys, Start/Stop, Forward/Reverse and Fault Reset Keys also LED's for "Current Limit", "Fwd/Rev", "Run" and "Fault."*
- * *50°C Ambient Temperature Rating (Nema 1 Enclosed Drives)*
- * *Tolerates High Input AC Line Voltages – 250/500/600 VAC +10% (240/480/575 VAC Input)*
- * *Ground Fault and Line to Line Short Circuit Protection*
- * *Programmable Speed Sensitive Motor Overload Protection to Comply with UL 508C Sections 43.3, 43.4 and 43.5*
- * *Speed Increase / Decrease (MOP) Function*
- * *S Curve Accel/Decel Control*



- * *User Programmable Auto-Restart Function*
- * *Bi-Directional Flycatcher (Start Into a Rotating Motor) – No Inertia Limits*
- * *Built In Kw / kWh Metering and Total Cost of Power Calculator*
- * *Programmable Time Based Function Generator and Programmable Threshold Detectors*
- * *Programmable time delay and logic functions (AND, OR, NOR) of bit parameters, digital inputs and outputs*
- * *Adding, subtracting, multiplying, dividing, ramping, limiting and/or filtering functions of parameters and analog inputs and outputs*
- * *Run Time and Power on Time Countdown Timers with Alarms plus Run Time and Power on Time Totalizers*
- * *Critical Speed Rejection, 3 Bands – Individually Programmable Bandwidth*
- * *Auto logging Fault History - Last 10 Faults Saved in Order of Occurrence*
- * *8 Digital Inputs, 24 VDC (7 Programmable Inputs and 1 Fixed Stop/Enable Input)*
- * *2 Programmable Digital Outputs – Two Form C Dry Contacts rated 5 Amps at 115VAC*
- * *2 Programmable Analog Input Signals, -10 VDC to +10 VDC or 4 to 20 ma*
- * *2 Programmable Analog Output Signals, -10 VDC to +10 VDC*
- * *DC Braking*
- * *Fixed or Variable Carrier Frequency*
- * *Much, Much, More..*

THREE YEAR WARRANTY

MADE IN USA

The Phoenix series of AC Drives was designed with one goal in mind: To create the most reliable and rugged Digital AC Drive on the market today. Reading through our standard features, it's easy to see the engineering detail that has made the Phoenix an outstanding product. To prove our commitment, we back each drive with a Three Year Warranty.

OUTSTANDING FEATURES

Open or Closed Loop Vector Control Phoenix ES is a High Performance AC Vector Drive. Without modification, it is an Open Loop Vector Drive. With the addition of Encoder Feedback, it becomes a Closed Loop Vector Drive. Vector Control offers improved low speed operation and a wider operating speed range. It also offers better Speed Regulation and true control of AC Motor Torque. When operating in the Closed Loop Mode, the Phoenix EX will hold Zero Speed and Hold Position.

High Voltage Ratings Line voltages in the United States are now averaging as high as 500VAC, in Canada that figure is 600VAC. Designing a product that doesn't take this fact into consideration will result in a product that will have power bridge failures or at best, nuisance overvoltage tripping. The Phoenix is rated to handle these new voltage averages with $\pm 10\%$ to spare!

Built In Radio Frequency Filter The RFI filter, that is standard in the Phoenix, reduces noise in the radio frequency band which may be generated by the drive. The R.F.I. filter has a secondary benefit of protecting the drive from high voltage transients which occur when attached to motors with long leads. Many drive manufacturers ignore these potential problems that can cause radio communications problems in a facility and weaken the integrity of the drive.

Input Line Suppression Metal oxide varistors are included on each unit to absorb line voltage transients, not only phase to phase, but also phase to ground. Without these suppression devices the drive's power semiconductors are exposed to high potential voltages.

Short Circuit Protection If any of the output phases are shorted together (motor stator failure) or if an output phase shorts to ground, the Phoenix will safely shut down protecting itself until the short is cleared. These types of conditions often occur during installation when a power lead is nicked and shorts to conduit.

50°C Ambient Temperature We know there are many places in North America where the ambient temperature can be very high during the summer months. Many products coming from overseas, however, have lowered their cost by providing a product that can only handle an ambient temperature of 104°F(40°C) in an enclosure. The Phoenix has been designed to handle the heat with a rating of 122°F(50°C) in a Nema type 1 enclosure.

Additional Standard Features:

- * **Backlit Keypad with Configurable Display**
- * **Motor Overload Protection - Meets NEC 430**
- * **Coast to Rest or Ramp Stop**
- * **Isolated Control Circuitry**
- * **Non-Volatile Parameter Storage**
- * **User Security Code**
- * **Programmable Auto Restart**
- * **S Curve Accel / Decel**
- * **Eight Preset Speeds**
- * **Eight Accel / Decel Rates**
- * **Two Timers with Alarms for Customer Use**
- * **Two Threshold Detectors for Customer Use**
- * **Setpoint Control with PID**
- * **DC Injection Braking**
- * **Critical Speed Rejection**
- * **Kw / Kwh Metering**

ENGINEERING DATA

Electrical Specifications:

Rated Input Voltage:	200-250Vac, 380-500Vac, 500-600Vac -15% of minimum, +10% of maximum.
Frequency Tolerance:	45-65 Hz
Number of Phases:	3
Displacement Power Factor:	.95 or greater
Efficiency:	97% or greater at rated current
Max. Short Circuit Current Rating:	200,000A rms symmetrical, 600 volts (when used with AC input line fuses specified in tables 1-1 to 1-3 of the Instruction Manual).

Control Specifications:

Control Method:	Sine coded PWM with programmable carrier. Space Vector control.
Output Voltage:	0 to rated voltage.
Output Frequency Range:	0 to 600 Hz.
Frequency accuracy:	Analog reference: 0.1% of max frequency. Digital reference: 0.01% of max frequency.
Frequency resolution:	Analog reference: 0.06Hz at 60Hz. Digital reference: 0.001Hz at 60Hz.
Accel/Decel:	0.1 to 3276 sec.
Drive overload:	At Constant Torque: 150% of drive rated output for 1 minute. At Variable Torque: 120% of drive rated output for 1 minute.
Inverse Time Overload:	Programmable motor overload protection to comply with N.E.C. Article 430.
Current limit:	Proactive current limit programmable in % of motor rated current.
Braking torque:	Approximately 20%.
Maximum connected motor:	2 times rated drive horsepower.

Environmental Specifications:

Ambient Temperature:	-10°C to 50°C (14°F to 122°F) Nema type 1 enclosed.
Storage Temperature:	-40°C to 70°C (-40°F to 158°F) Nema type 1 enclosed.
Altitude:	Sea level to 3300 Feet [1000m] without derating.
Humidity:	95% relative humidity non-condensing.
Vibration:	9.8m/sec ² (1.0G) peak.
Immunity:	IEEE C62.41-1991 Category B (Formerly known as IEEE 587) EN50082-2 (Generic Immunity Standard).
Input R.F.I. Filter:	Standard on all models.

Physical attributes:

Mounting:	Though hole or panel mount for size 0 to size 3 drives. Size 4 drives are free standing enclosure.
Nema Rating:	Type 1 (IP20) as standard, Type 12 (IP54) optional.
Construction:	Steel construction (reduces E.M.I.)

Protective Features:

- Programmable motor overload protection to comply with UL 508C sections 43.3, 43.4 and 43.5.
- Drive overload protection to protect inverter.
- Motor stall protection at acceleration /deceleration and constant speed operation.
- Peak output current monitoring to protect against line-to-line shorts and line-to-ground shorts.
- Heatsink over-temperature monitoring.
- AC line overvoltage protection.

- DC bus over-voltage protection.
- DC bus under-voltage protection.
- Programmable stall protection.
- Internal power supply monitoring.
- AC power loss detection.
- Critical speed rejection with programmable 3 points with bandwidth to avoid mechanical resonance.
- Flycatcher "catch a spinning motor".
- Password protection to prevent parameter changes by unauthorized personnel.
- 4 to 20ma reference loss detection.
- Programmable thresholds and more.

Control I/O:

- 8 Digital Inputs: 7 user programmable inputs and 1 dedicated input for "Stop", rated for 24Vdc logic control.
- 2 Digital Outputs: 2 programmable dry contacts rated 115Vac @ 5A; 30Vdc @ 3.5A.
- 2 Analog Inputs: -10 to +10V (10 bits) with 75K Ω input impedance or 4-20 mA @ 500 Ω - Programmable.
- 2 Analog Outputs: -10 to +10V (10 bits) @ 2 mA max with output impedance = 100 Ω . - Programmable.
- 1 Voltage Reference: +15Vdc reference @ 10 mA max.
- 24Vdc source: Use to power operator pushbuttons and US Drives, Inc. option boards: 24Vdc @ 80 mA max.

Standard Drives Features:

- New generation IGBT.
- Nema type 1 (IP20) as standard for all models.
- 50°C ambient with standard Nema type 1 (IP20) enclosure.
- High voltage ratings: 250Vac+10% , 500Vac+10% models and 600Vac+10% models
- Modbus RTU serial communications ready.
- Input line suppression: Metal oxide varistors for line-to-line and line-to-ground voltage surge protection.
- Built-in radio frequency filter.
- Nonvolatile parameter storage.
- All parameters are saved in EEPROM (nonvolatile).
- Auto logging fault history: ten last faults recorded in order of occurrence.
- Simple programming through the Real-time Operator module (R.O.M.) with all data entries and monitoring in engineering units with English descriptions.
- Injection DC Braking with braking time calculated automatically by the drive.
- Critical speed rejection.
- Programmable auto restart.
- Parameter security code.
- User definable displays with programmable format and parameter scaling.
- 7 programmable digital inputs for custom setups.
- Metering: AC line voltage, motor current, motor voltage, DC Bus voltage, Kw, Kwh, running Kwh cost and more...
- 8 programmable digital preset speeds with user selectable acceleration and deceleration rates.
- M.O.P. function.
- Programmable PWM carrier frequency, fixed or variable.
- Programmable Time Based Function Generator and Programmable Threshold Detectors
- Run Time and Power on Time Countdown Timers with Alarms plus Run Time and Power on Time Totalizers
- Bi-directional auto-speed search (flycatcher) for starting into rotating loads.
- S-curve accel/decel control.
- Programmable time delay and logic functions (AND, OR, NOR) of bit parameters, digital inputs and outputs.
- Adding, subtracting, multiplying, dividing, ramping, limiting and/or filtering functions of parameters and analog inputs and outputs.
- Parameters can be displayed, routed to an analog/digital output or re-routed and used as an input parameter to control another function within the drive.
- User programmable functions and modes.
- Open Loop or closed-loop control operation easy setup.
- Precise control of motor speed and torque.
- Rigid and non-rigid position control including orientation.
- Induction and permanent magnet motor control.

CATALOG NUMBER EXPLANATION

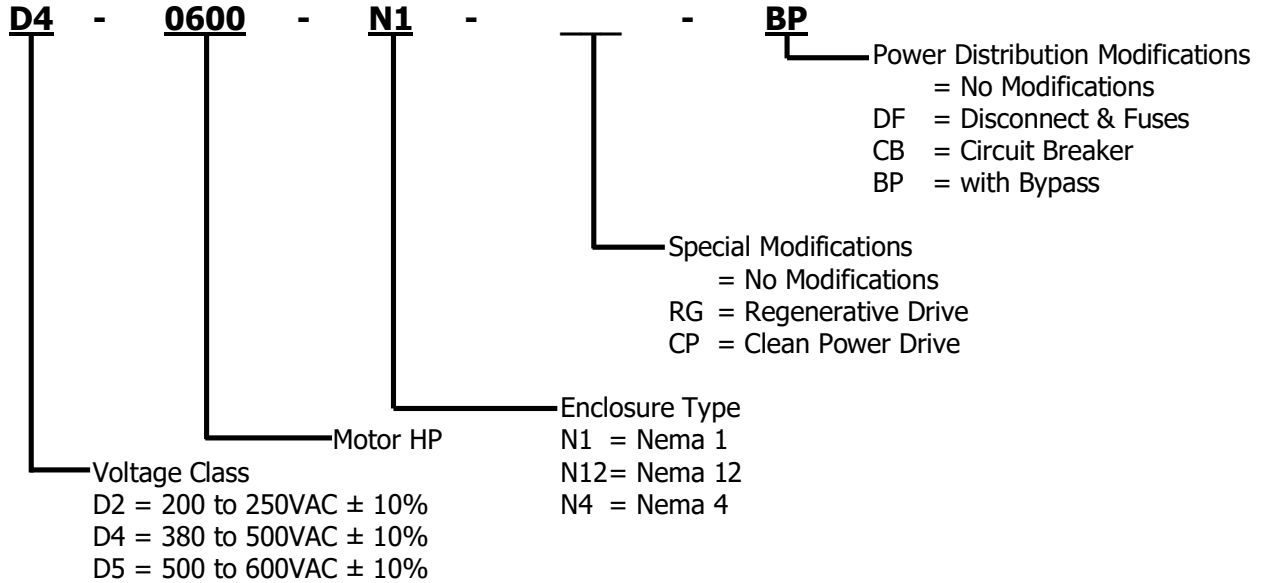

CATALOG NUMBER SELECTION / RATING TABLES

200-250VAC (-10% to +10%)												
Frame Designation	NEMA 1 (IP20) Catalog Number	Motor HP ¹		Output Current (Amps)		Output KVA ⁴		Input Current (Amps)		Input KVA ⁴		Maximum Recommended AC Line Fuses ⁵ (Amps)
		High Overload Capacity HT ²	Normal Overload Capacity NT ³	High Overload Capacity HT ²	Normal Overload Capacity NT ³	High Overload Capacity HT ²	Normal Overload Capacity NT ³	High Overload Capacity HT ²	Normal Overload Capacity NT ³	High Overload Capacity HT ²	Normal Overload Capacity NT ³	
SIZE 0	D2-0005-N1	3	5	10	16	4	7	12	19	5	8	35
	D2-0007-N1	5	7.5	16	22	7	9	19	25	8	10	40
	D2-0010-N1	7.5	10	22	28	9	12	25	33	10	14	50
	D2-0015-N1	10	15	28	42	12	17	25	36	10	15	60
	D2-0020-N1	15	20	42	54	17	22	36	50	15	21	70
	D2-0020CT-N1	20	-	54	-	22	-	50	-	21	-	70
SIZE 1	D2-0025-N1	20	25	54	68	22	28	50	61	21	25	90
	D2-0030-N1	25	30	68	85	28	35	61	79	25	33	100
	D2-0030CT-N1	30	-	80	-	33	-	74	-	31	-	100
SIZE 2	D2-0040-N1	30	40	80	104	33	43	74	96	31	40	150
	D2-0050-N1	40	50	104	130	43	54	96	120	40	50	200
	D2-0060-N1	50	60	130	163	54	68	120	155	50	64	250
	D2-0075-N1	60	75	154	192	60	80	140	186	58	77	300
	D2-0100-N1	75	100	192	248	80	103	186	230	77	96	300
	D2-0100CT-N1	100	-	248	-	103	-	230	-	96	-	300
SIZE 3	D2-0125VT-N1	-	125	-	312	-	130	-	290	-	121	⁶
	D2-0125CT-N1	125	-	312	-	130	-	290	-	121	-	⁶
	D2-0150VT-N1	-	150	-	360	-	150	-	335	-	139	⁶
	D2-0150CT-N1	150	-	360	-	150	-	335	-	139	-	⁶
	D2-0200VT-N1	-	200	-	480	-	200	-	446	-	186	⁶
	D2-0200CT-N1	200	-	480	-	200	-	446	-	186	-	⁶
	D2-250VT-N1	-	250	-	602	-	250	-	560	-	233	⁶
	D2-0250CT-N1	250	-	602	-	250	-	560	-	233	-	⁶

¹ Horsepower rating based on 230 VAC Motors.
² High Overload Capacity Drives (HT) produce 150% of Rated Drive Output Current for 1 minute.
³ Normal Overload Capacity Drive (NT) produce 120% of Rated Drive Output Current for 1 minute.
⁴ Output and Input KVA at nominal 240 VAC.
⁵ UL Class T, J and Semiconductor Fuses (preferred): Ferraz Shawmut A50Q, Bussmann FWH.
⁶ Included as standard.

CATALOG NUMBER SELECTION / RATING TABLES

380-500VAC (-10% to +10%)												
Frame Designation	NEMA 1 (IP20) Catalog Number	Motor HP ¹		Output Current (Amps)		Output KVA ⁴		Input Current (Amps)		Input KVA ⁴		Maximum Recommended AC Line Fuses ⁵ (Amps)
		High Overload Capacity HT ²	Normal Overload Capacity NT ³	High Overload Capacity HT ²	Normal Overload Capacity NT ³	High Overload Capacity HT ²	Normal Overload Capacity NT ³	High Overload Capacity HT ²	Normal Overload Capacity NT ³	High Overload Capacity HT ²	Normal Overload Capacity NT ³	
SIZE 0	D4-0007-N1	5	7.5	8	11	7	9	10	13	8	11	25
	D4-0010-N1	7.5	10	11	14	9	12	13	17	11	14	30
	D4-0015-N1	10	15	14	21	12	17	17	25	14	21	40
	D4-0020-N1	15	20	21	27	17	22	25	33	21	27	50
	D4-0025-N1	20	25	27	34	22	28	26	31	22	26	50
	D4-0030-N1	25	30	34	43	28	36	31	38	26	32	60
	D4-0040-N1	30	40	40	52	33	43	36	48	30	40	70
D4-0040CT-N1	40	-	52	-	43	-	48	-	40	-	-	70
SIZE 1	D4-0050-N1	40	50	52	66	43	55	48	56	40	47	90
	D4-0060-N1	50	60	65	82	54	68	56	72	47	60	100
	D4-0060CT-N1	60	-	77	-	64	-	67	-	56	-	100
SIZE 2	D4-0075-N1	60	75	77	97	64	81	67	83	56	69	125
	D4-0100-N1	75	100	96	124	80	103	86	110	71	91	175
	D4-0125-N1	100	125	124	156	103	130	110	139	91	116	200
	D4-0150-N1	125	150	156	180	130	150	139	163	116	136	250
	D4-0200-N1	150	200	180	240	150	200	167	223	139	186	350
D4-0200CT-N1	200	-	240	-	200	-	223	-	186	-	-	350
SIZE 3	D4-250VT-N1	-	250	-	302	-	251	-	281	-	234	6
	D4-0250CT-N1	250	-	302	-	251	-	281	-	234	-	6
	D4-0300VT-N1	-	300	-	361	-	300	-	336	-	279	6
	D4-0300CT-N1	300	-	361	-	300	-	336	-	279	-	6
	D4-0350VT-N1	-	350	-	414	-	344	-	385	-	320	6
	D4-0350CT-N1	350	-	414	-	344	-	385	-	320	-	6
	D4-0400VT-N1	-	400	-	477	-	397	-	444	-	369	6
	D4-0400CT-N1	400	-	477	-	397	-	444	-	369	-	6
	D4-0450VT-N1	-	450	-	540	-	449	-	503	-	418	6
	D4-0450CT-N1	450	-	540	-	449	-	503	-	418	-	6
	D4-0500VT-N1	-	500	-	600	-	499	-	558	-	464	6
	D4-0500CT-N1	500	-	600	-	499	-	558	-	464	-	6
	SIZE 4	D4-0600VT-N1	-	600	-	720	-	599	-	670	-	557
D4-0600CT-N1		600	-	720	-	599	-	670	-	557	-	6
D4-0700VT-N1		-	700	-	840	-	698	-	781	-	649	6
D4-0700CT-N1		700	-	840	-	698	-	781	-	649	-	6
D4-0800VT-N1		-	800	-	960	-	798	-	893	-	742	6
D4-0800CT-N1		800	-	960	-	798	-	893	-	742	-	6
D4-0900VT-N1		-	900	-	1080	-	898	-	1004	-	835	6
D4-0900CT-N1		900	-	1080	-	898	-	1004	-	835	-	6
D4-1000VT-N1		-	1000	-	1200	-	998	-	1116	-	928	6
D4-1000CT-N1		1000	-	1200	-	998	-	1116	-	928	-	6
D4-1250VT-N1		-	1250	-	1500	-	1247	-	1395	-	1160	6
D4-1250CT-N1		1250	-	1500	-	1247	-	1395	-	1160	-	6
D4-1500VT-N1		-	1500	-	1800	-	1496	-	1674	-	1392	6
D4-1500CT-N1		1500	-	1800	-	1496	-	1674	-	1392	-	6
D4-1750VT-N1		-	1750	-	2100	-	1746	-	1953	-	1624	6
D4-1750CT-N1		1750	-	2100	-	1746	-	1953	-	1624	-	6
D4-2000VT-N1		-	2000	-	2400	-	1995	-	2232	-	1856	6
D4-2000CT-N1	2000	-	2400	-	1995	-	2232	-	1856	-	6	
D4-2500VT-N1	-	2500	-	3000	-	2494	-	2790	-	2320	6	
D4-2500CT-N1	2500	-	3000	-	2494	-	2790	-	2320	-	6	

THIS VOLTAGE SERIES HAS A MAXIMUM HP RATING OF 3,000HP

¹ Horsepower rating based on 460 VAC Motors.

² High Overload Capacity Drives (HT) produce 150% of Rated Drive Output Current for 1 minute.

³ Normal Overload Capacity Drive (NT) produce 120% of Rated Drive Output Current for 1 minute.

⁴ Output and Input KVA at nominal 240 VAC.

⁵ UL Class T, J and Semiconductor Fuses (preferred): Ferraz Shawmut A50Q, Bussmann FWH.

⁶ Included as standard.

CATALOG NUMBER SELECTION / RATING TABLES

500-600VAC (-10% to +10%)												
Frame Designation	NEMA 1 (IP20) Catalog Number	Motor HP ¹		Output Current (Amps)		Output KVA ⁴		Input Current (Amps)		Input KVA ⁴		Maximum Recommended AC Line Fuses ⁵ (Amps)
		High Overload Capacity HT ²	Normal Overload Capacity NT ³	High Overload Capacity HT ²	Normal Overload Capacity NT ³	High Overload Capacity HT ²	Normal Overload Capacity NT ³	High Overload Capacity HT ²	Normal Overload Capacity NT ³	High Overload Capacity HT ²	Normal Overload Capacity NT ³	
SIZE 0	D5-0007-N1	5	7.5	7	9	7	9	9	11	9	11	20
	D5-0010-N1	7.5	10	9	12	9	12	11	13	11	13	25
	D5-0015-N1	10	15	11	17	11	17	13	20	13	20	35
	D5-0020-N1	15	20	17	22	17	22	20	25	20	25	40
	D5-0025-N1	20	25	22	28	22	28	22	28	22	28	40
	D5-0030-N1	25	30	27	34	27	34	27	34	27	34	50
	D5-0040-N1	30	40	32	41	32	41	32	40	32	40	60
D5-0040CT-N1	40	-	41	-	41	-	40	-	40	-	-	60
SIZE 1	D5-0050-N1	40	50	41	52	41	52	40	48	40	48	80
	D5-0060-N1	50	60	52	65	52	65	54	61	54	61	90
	D5-0075-N1	60	75	62	78	62	78	58	72	58	72	100
	D5-0075CT-N1	75	-	77	-	77	-	75	-	75	-	150
SIZE 2	D5-0100-N1	75	100	77	99	77	99	75	96	75	96	150
	D5-0125-N1	100	125	99	125	99	124	96	124	96	123	175
	D5-0150-N1	125	150	125	157	124	156	124	154	123	153	200
	D5-0200-N1	150	200	144	192	143	191	142	191	141	190	300
	D5-0200CT-N1	200	-	192	-	191	-	191	-	190	-	300
SIZE 3	D5-250VT-N1	-	250	-	242	-	241	-	240	-	239	6
	D5-0250CT-N1	250	-	242	-	241	-	240	-	239	-	6
	D5-0300VT-N1	-	300	-	289	-	288	-	286	-	285	6
	D5-0300CT-N1	300	-	289	-	288	-	286	-	285	-	6
	D5-0350VT-N1	-	350	-	336	-	335	-	333	-	331	6
	D5-0350CT-N1	350	-	336	-	335	-	333	-	331	-	6
	D5-0400VT-N1	-	400	-	382	-	380	-	378	-	377	6
	D5-0400CT-N1	400	-	382	-	380	-	378	-	377	-	6
	D5-0450VT-N1	-	450	-	432	-	430	-	428	-	426	6
	D5-0450CT-N1	450	-	432	-	430	-	428	-	426	-	6
	D5-0500VT-N1	-	500	-	472	-	470	-	467	-	465	6
	D5-0500CT-N1	500	-	472	-	470	-	467	-	465	-	6
	D5-0600VT-N1	-	600	-	576	-	574	-	570	-	568	6
	D5-0600CT-N1	600	-	576	-	574	-	570	-	568	-	6
	SIZE 4	D5-0700VT-N1	-	700	-	672	-	669	-	665	-	663
D5-0700CT-N1		700	-	672	-	669	-	665	-	663	-	6
D5-0800VT-N1		-	800	-	768	-	765	-	760	-	757	6
D5-0800CT-N1		800	-	768	-	765	-	760	-	757	-	6
D5-0900VT-N1		-	900	-	864	-	860	-	855	-	852	6
D5-0900CT-N1		900	-	864	-	860	-	855	-	852	-	6
D5-1000VT-N1		-	1000	-	960	-	956	-	950	-	947	6
D5-1000CT-N1		1000	-	960	-	956	-	950	-	947	-	6
D5-1250VT-N1		-	1250	-	1200	-	1195	-	1188	-	1183	6
D5-1250CT-N1		1250	-	1200	-	1195	-	1188	-	1183	-	6
D5-1500VT-N1		-	1500	-	1440	-	1434	-	1426	-	1420	6
D5-1500CT-N1		1500	-	1440	-	1434	-	1426	-	1420	-	6
D5-1750VT-N1		-	1750	-	1680	-	1673	-	1663	-	1656	6
D5-1750CT-N1		1750	-	1680	-	1673	-	1663	-	1656	-	6
D5-2000VT-N1		-	2000	-	1920	-	1912	-	1901	-	1893	6
D5-2000CT-N1	2000	-	1920	-	1912	-	1901	-	1893	-	6	
D5-2500VT-N1	-	2500	-	2400	-	2390	-	2376	-	2366	6	
D5-2500CT-N1	2500	-	2400	-	2390	-	2376	-	2366	-	6	

THIS VOLTAGE SERIES HAS A MAXIMUM HP RATING OF 3,500HP

¹ Horsepower rating based on 575 VAC Motors.

² High Overload Capacity Drives (HT) produce 150% of Rated Drive Output Current for 1 minute.

³ Normal Overload Capacity Drive (NT) produce 120% of Rated Drive Output Current for 1 minute.

⁴ Output and Input KVA at nominal 240 VAC.

⁵ UL Class T, CC, J, and Semiconductor Fuses (preferred): Ferraz Shawmut A70Q, Bussmann FWP.

⁶ Included as standard.

Dimensions - Nema 1 Enclosed VFD Only

Input Voltage	Motor HP		Approximate Dimensions (HxWxD)	Figure	Mounting	Approximate Weight
	High Overload Capacity (HT)	Normal Overload Capacity (NT)				
200 - 250 VAC (208/230/240)	3 - 7.5	5 - 10	13.05" x 9.0" x 10.9"	1	Wall	30 Lbs.
	10 - 20	15 - 20	13.05" x 9.0" x 10.9"	1	Wall	30 Lbs.
	25 - 30	25 - 30	25" x 11.6" x 11.1"	2	Wall	75 Lbs.
	40 - 100	40 - 100	32.5" x 20.1" x 13.5"	3	Wall	180 Lbs.
	125 - 250	125 - 250	44.2" x 31.1" x 16.8"	4	Wall	500 Lbs.
	Above 250	Above 250	Consult Factory	-	-	-
380 - 500 VAC (380/400/415/480)	5 - 15	7.5 - 20	13.05" x 9.0" x 10.9"	1	Wall	30 Lbs.
	20 - 40	25 - 40	13.05" x 9.0" x 10.9"	1	Wall	30 Lbs.
	50 - 60	50 - 60	25" x 11.6" x 11.1"	2	Wall	75 Lbs.
	75 - 200	75 - 200	32.5" x 20.1" x 13.5"	3	Wall	180 Lbs.
	250 - 500	250 - 500	44.2" x 31.1" x 16.8"	4	Wall	500 Lbs.
	600 - 1000	600 - 1000	72" x 72" x 23.5"	6	Floor	1800 Lbs.
Above 1000	Above 1000	Consult Factory	-	-	-	
525 - 600 VAC (525/575/600)	5 - 15	7.5 - 20	13.05" x 9.0" x 10.9"	1	Wall	30 Lbs.
	20 - 40	25 - 40	13.05" x 9.0" x 10.9"	1	Wall	30 Lbs.
	50 - 75	50 - 75	25" x 11.6" x 11.1"	2	Wall	75 Lbs.
	100 - 200	100 - 200	32.5" x 20.1" x 13.5"	3	Wall	180 Lbs.
	250 - 600	250 - 600	44.2" x 31.1" x 16.8"	4	Wall	500 Lbs.
	700 - 1200	700 - 1200	72" x 72" x 23.5"	6	Floor	1800 Lbs.
Above 1200	Above 1200	Consult Factory	-	-	-	

Dimensions - Nema 12 Enclosed VFD Only

Input Voltage	Motor HP		Approximate Dimensions (HxWxD)	Figure	Mounting	Approximate Weight
	High Overload Capacity (HT)	Normal Overload Capacity (NT)				
200 - 250 VAC (208/230/240)	3 - 7.5	5 - 10	13.05" x 9.0" x 10.9"	1	Wall	35 Lbs.
	10 - 20	15 - 20	13.05" x 9.0" x 10.9"	1	Wall	35 Lbs.
	25 - 30	25 - 30	25" x 11.6" x 11.1"	2	Wall	80 Lbs.
	40 - 100	40 - 100	32.5" x 20.1" x 13.5"	3	Wall	185 Lbs.
	125 - 250	125 - 250	72" x 36" x 23.5"	5	Floor	870 Lbs.
	Above 250	Above 250	Consult Factory	-	-	-
380 - 500 VAC (380/400/415/480)	5 - 15	7.5 - 20	13.05" x 9.0" x 10.9"	1	Wall	35 Lbs.
	20 - 40	25 - 40	13.05" x 9.0" x 10.9"	1	Wall	35 Lbs.
	50 - 60	50 - 60	25" x 11.6" x 11.1"	2	Wall	80 Lbs.
	75 - 200	75 - 200	32.5" x 20.1" x 13.5"	3	Wall	185 Lbs.
	250 - 500	250 - 500	72" x 36" x 23.5"	5	Floor	870 Lbs.
	600 - 1000	600 - 1000	72" x 72" x 23.5"	6	Floor	1800 Lbs.
Above 1000	Above 1000	Consult Factory	-	-	-	
525 - 600 VAC (525/575/600)	5 - 15	7.5 - 20	13.05" x 9.0" x 10.9"	1	Wall	35 Lbs.
	20 - 40	25 - 40	13.05" x 9.0" x 10.9"	1	Wall	35 Lbs.
	50 - 75	50 - 75	25" x 11.6" x 11.1"	2	Wall	80 Lbs.
	100 - 200	100 - 200	32.5" x 20.1" x 13.5"	3	Wall	185 Lbs.
	250 - 600	250 - 600	72" x 36" x 23.5"	5	Floor	870 Lbs.
	700 - 1200	700 - 1200	72" x 72" x 23.5"	6	Floor	1800 Lbs.
Above 1200	Above 1200	Consult Factory	-	-	-	

PHOENIX ES

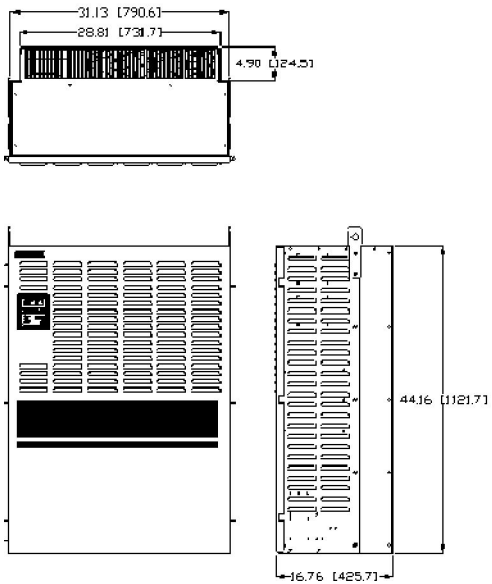
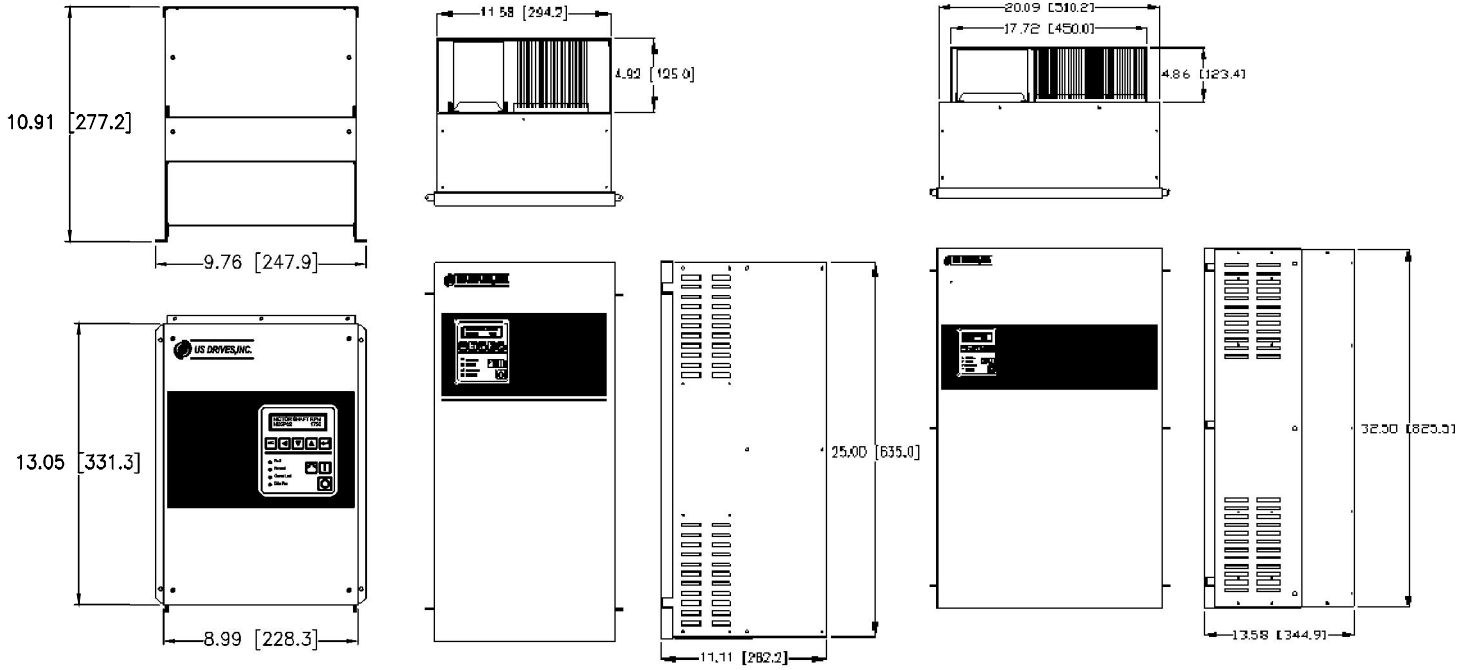

Figure 4

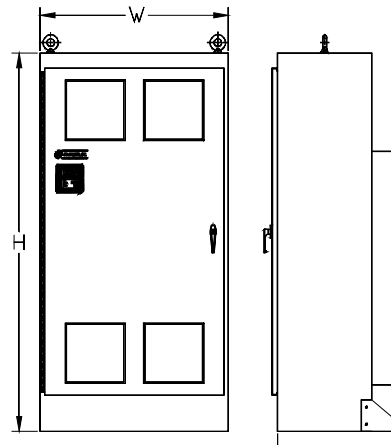

Figure 5

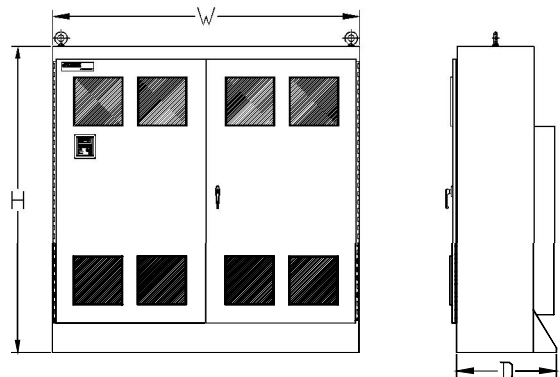

Figure 6

Dimensions - Nema 1 Enclosed VFD with Input Disconnect & Fuses

Input Voltage	Motor HP		Approximate Dimensions (HxWxD)	Figure	Mounting	Approximate Weight
	High Overload Capacity (HT)	Normal Overload Capacity (NT)				
200 - 250 VAC (208/230/240)	3 - 7.5	5 - 10	20.74" x 9.0" x 10.9"	7	Wall	46 Lbs.
	10 - 20	15 - 20	20.74" x 9.0" x 10.9"	7	Wall	46 Lbs.
	25 - 30	25 - 30	25" x 11.6" x 11.1"	8	Wall	85 Lbs.
	40 - 100	40 - 100	32.5" x 20.1" x 13.5"	9	Wall	190 Lbs.
	125 - 250	125 - 250	72" x 31.5" x 18"	11	Wall	700 Lbs.
	Above 250	Above 250	Consult Factory	-	-	-
380 - 500 VAC (380/400/415/480)	5 - 15	7.5 - 20	20.74" x 9.0" x 10.9"	7	Wall	46 Lbs.
	20 - 40	25 - 40	20.74" x 9.0" x 10.9"	7	Wall	46 Lbs.
	50 - 60	50 - 60	25" x 11.6" x 11.1"	8	Wall	85 Lbs.
	75 - 200	75 - 200	32.5" x 20.1" x 13.5"	9	Wall	190 Lbs.
	250 - 500	250 - 500	72" x 31.5" x 18"	11	Wall	700 Lbs.
	600 - 1000	600 - 1000	90" x 72" x 25.5"	12	Floor	1950 Lbs.
Above 1000	Above 1000	Consult Factory	-	-	-	
525 - 600 VAC (525/575/600)	5 - 15	7.5 - 20	20.74" x 9.0" x 10.9"	7	Wall	46 Lbs.
	20 - 40	25 - 40	20.74" x 9.0" x 10.9"	7	Wall	46 Lbs.
	50 - 75	50 - 75	25" x 11.6" x 11.1"	8	Wall	85 Lbs.
	100 - 200	100 - 200	32.5" x 20.1" x 13.5"	9	Wall	190 Lbs.
	250 - 600	250 - 600	72" x 31.1" x 18"	11	Wall	700 Lbs.
	700 - 1200	700 - 1200	90" x 72" x 25.5"	12	Floor	1950 Lbs.
Above 1200	Above 1200	Consult Factory	-	-	-	

Dimensions - Nema 12 Enclosed VFD with Input Disconnect & Fuses

Input Voltage	Motor HP		Approximate Dimensions (HxWxD)	Figure	Mounting	Approximate Weight
	High Overload Capacity (HT)	Normal Overload Capacity (NT)				
200 - 250 VAC (208/230/240)	3 - 7.5	5 - 10	20.74" x 9.0" x 10.9"	7	Wall	50 Lbs.
	10 - 20	15 - 20	20.74" x 9.0" x 10.9"	7	Wall	50 Lbs.
	25 - 30	25 - 30	25" x 11.6" x 11.1"	8	Wall	90 Lbs.
	40 - 100	40 - 100	32.5" x 20.1" x 13.5"	9	Wall	190 Lbs.
	125 - 250	125 - 250	72" x 36" x 23.5"	10	Floor	900 Lbs.
	Above 250	Above 250	Consult Factory	-	-	-
380 - 500 VAC (380/400/415/480)	5 - 15	7.5 - 20	20.74" x 9.0" x 10.9"	7	Wall	50 Lbs.
	20 - 40	25 - 40	20.74" x 9.0" x 10.9"	7	Wall	50 Lbs.
	50 - 60	50 - 60	25" x 11.6" x 11.1"	8	Wall	90 Lbs.
	75 - 200	75 - 200	32.5" x 20.1" x 13.5"	9	Wall	190 Lbs.
	250 - 500	250 - 500	72" x 36" x 23.5"	10	Floor	900 Lbs.
	600 - 1000	600 - 1000	90" x 72" x 25.5"	12	Floor	1950 Lbs.
Above 1000	Above 1000	Consult Factory	-	-	-	
525 - 600 VAC (525/575/600)	5 - 15	7.5 - 20	20.74" x 9.0" x 10.9"	7	Wall	50 Lbs.
	20 - 40	25 - 40	20.74" x 9.0" x 10.9"	7	Wall	50 Lbs.
	50 - 75	50 - 75	25" x 11.6" x 11.1"	8	Wall	90 Lbs.
	100 - 200	100 - 200	32.5" x 20.1" x 13.5"	9	Wall	190 Lbs.
	250 - 600	250 - 600	72" x 36" x 23.5"	10	Floor	900 Lbs.
	700 - 1200	700 - 1200	90" x 72" x 25.5"	12	Floor	1950 Lbs.
Above 1200	Above 1200	Consult Factory	-	-	-	

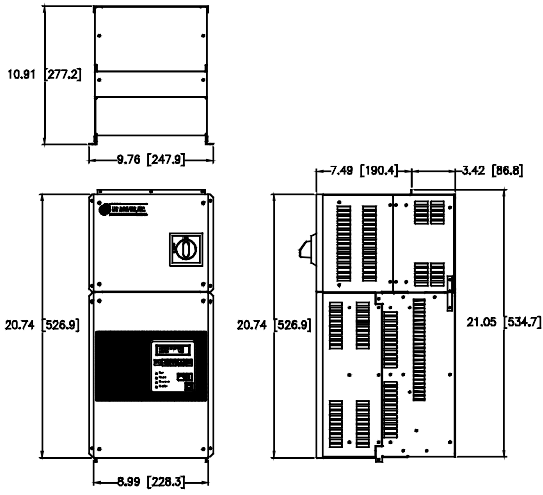

Figure 7

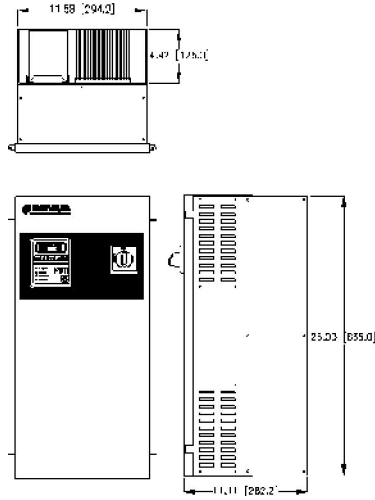

Figure 8

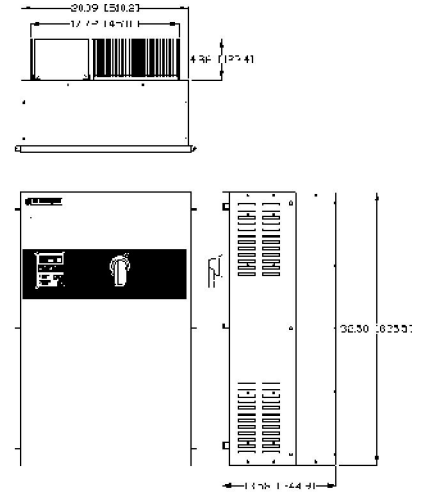

Figure 9

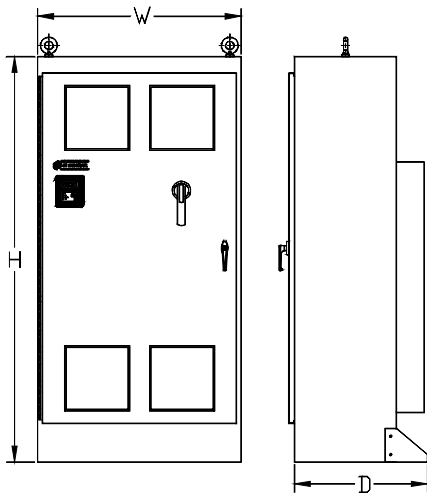

Figure 10

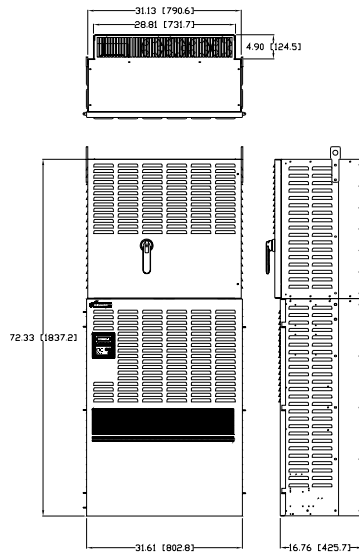

Figure 11

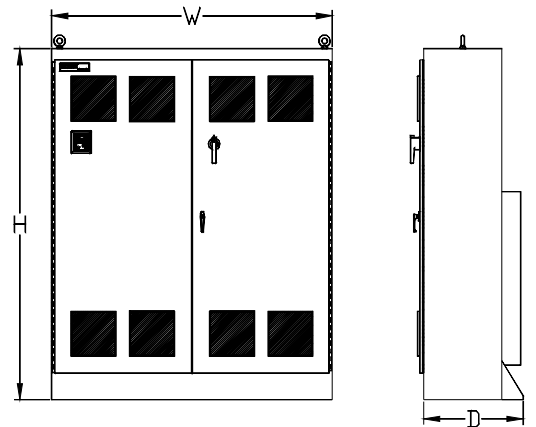

Figure 12

Dimensions - Nema 1 Enclosed VFD with Manual Contactor Bypass

Input Voltage	Motor HP		Approximate Dimensions (HxWxD)	Figure	Mounting	Approximate Weight
	High Overload Capacity (HT)	Normal Overload Capacity (NT)				
200 - 250 VAC (208/230/240)	3 - 7.5	5 - 10	34.02" x 9.0" x 10.9"	13	Wall	79 Lbs.
	10 - 20	15 - 20	34.02" x 9.0" x 10.9"	13	Wall	79 Lbs.
	25 - 30	25 - 30	38.4" x 11.6" x 11.1"	14	Wall	120 Lbs.
	40 - 100	40 - 100	65" x 20.1" x 13.5"	15	Wall	250 Lbs.
	125 - 200	125 - 200	72" x 72" x 23.5"	17	Floor	1400 Lbs.
	250	250	72" x 72" x 23.5"	17	Floor	1700 Lbs.
	Above 250	Above 250	Consult Factory	-	-	-
380 - 500 VAC (380/400/415/480)	5 - 15	7.5 - 20	34.02" x 9.0" x 10.9"	13	Wall	79 Lbs.
	20 - 40	25 - 40	34.02" x 9.0" x 10.9"	13	Wall	79 Lbs.
	50 - 60	50 - 60	38.4" x 11.6" x 11.1"	14	Wall	120 Lbs.
	75 - 200	75 - 200	65" x 20.1" x 13.5"	15	Wall	250 Lbs.
	250 - 400	250 - 400	72" x 72" x 23.5"	17	Floor	1400 Lbs.
	450 - 500	450 - 500	72" x 72" x 23.5"	17	Floor	1700 Lbs.
	600 - 1000	600 - 1000	Consult Factory	-	-	-
Above 1000	Above 1000	Consult Factory	-	-	-	
525 - 600 VAC (525/575/600)	5 - 15	7.5 - 20	24" x 24" x 14.2"	16	Wall	85 Lbs.
	20 - 40	25 - 40	24" x 30" x 14.2"	16	Wall	95 Lbs.
	50 - 75	50 - 75	38.4" x 11.6" x 11.1"	14	Wall	120 Lbs.
	100 - 200	100 - 200	65" x 20.1" x 13.5"	15	Wall	250 Lbs.
	250 - 400	250 - 400	72" x 72" x 23.5"	17	Floor	1400 Lbs.
	450 - 600	450 - 600	72" x 72" x 23.5"	17	Floor	1700 Lbs.
	700 - 1200	700 - 1200	Consult Factory	-	-	-
Above 1200	Above 1200	Consult Factory	-	-	-	

Dimensions - Nema 12 Enclosed VFD with Manual Contactor Bypass

Input Voltage	Motor HP		Approximate Dimensions (HxWxD)	Figure	Mounting	Approximate Weight
	High Overload Capacity (HT)	Normal Overload Capacity (NT)				
200 - 250 VAC (208/230/240)	3 - 7.5	5 - 10	34.02" x 9.0" x 10.9"	13	Wall	85 Lbs.
	10 - 20	15 - 20	34.02" x 9.0" x 10.9"	13	Wall	85 Lbs.
	25 - 30	25 - 30	38.4" x 11.6" x 11.1"	14	Wall	125 Lbs.
	40 - 100	40 - 100	65" x 20.1" x 13.5"	15	Wall	255 Lbs.
	125 - 200	125 - 200	72" x 72" x 23.5"	17	Floor	1450 Lbs.
	250	250	72" x 72" x 23.5"	17	Floor	1750 Lbs.
	Above 250	Above 250	Consult Factory	-	-	-
380 - 500 VAC (380/400/415/480)	5 - 15	7.5 - 20	34.02" x 9.0" x 10.9"	13	Wall	85 Lbs.
	20 - 40	25 - 40	34.02" x 9.0" x 10.9"	13	Wall	85 Lbs.
	50 - 60	50 - 60	38.4" x 11.6" x 11.1"	14	Wall	125 Lbs.
	75 - 200	75 - 200	65" x 20.1" x 13.5"	15	Wall	255 Lbs.
	250 - 400	250 - 400	72" x 72" x 23.5"	17	Floor	1450 Lbs.
	450 - 500	450 - 500	72" x 72" x 23.5"	17	Floor	1750 Lbs.
	600 - 1000	600 - 1000	Consult Factory	-	-	-
Above 1000	Above 1000	Consult Factory	-	-	-	
525 - 600 VAC (525/575/600)	5 - 15	7.5 - 20	24" x 24" x 14.2"	16	Wall	85 Lbs.
	20 - 40	25 - 40	24" x 30" x 14.2"	16	Wall	95 Lbs.
	50 - 75	50 - 75	38.4" x 11.6" x 11.1"	14	Wall	125 Lbs.
	100 - 200	100 - 200	65" x 20.1" x 13.5"	15	Wall	255 Lbs.
	250 - 400	250 - 400	72" x 72" x 23.5"	17	Floor	1450 Lbs.
	450 - 600	450 - 600	72" x 72" x 23.5"	17	Floor	1750 Lbs.
	700 - 1200	700 - 1200	Consult Factory	-	-	-
Above 1200	Above 1200	Consult Factory	-	-	-	

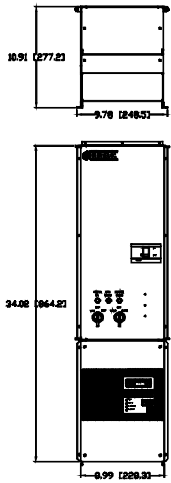

Figure 13

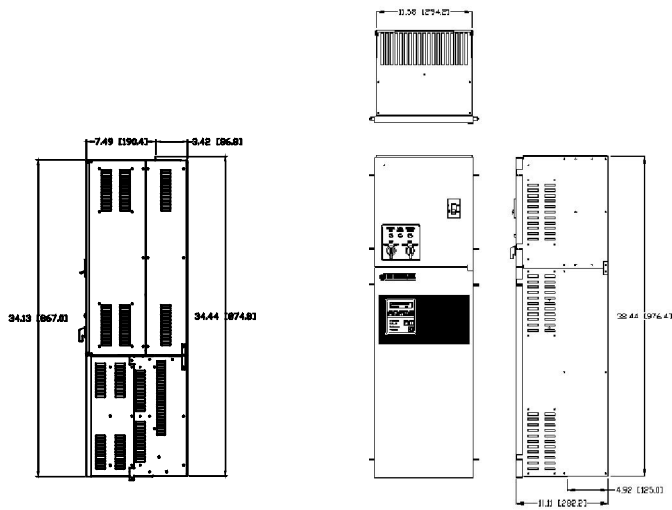

Figure 14

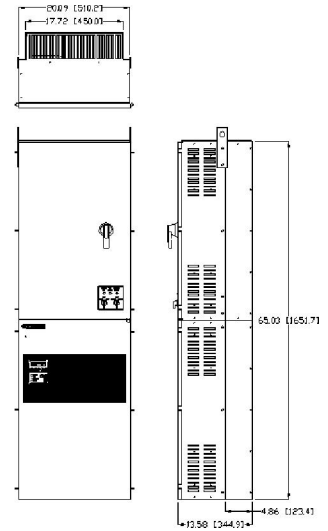

Figure 15

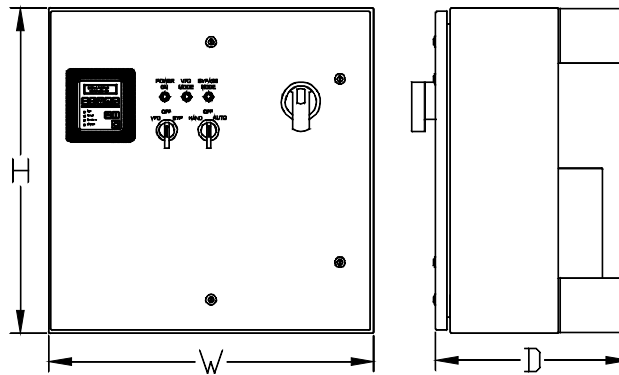

Figure 16

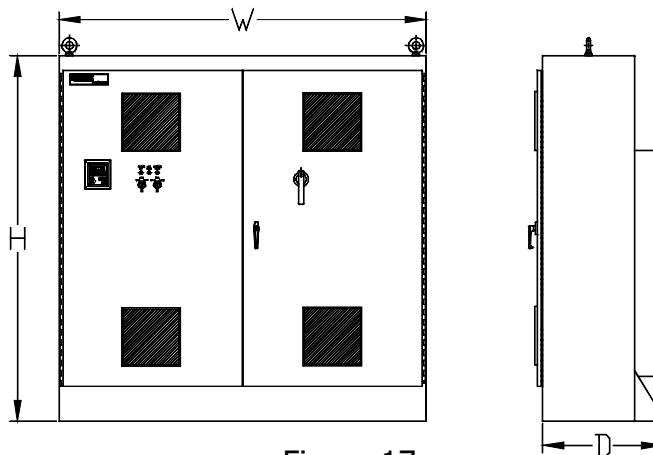

Figure 17

Phoenix DS Clean Power (18 Pulse) AC Drive

Poor power quality can be costly. Nonlinear loads, including AC Drives, introduce undesirable harmonic currents into the power system that can damage equipment, increase downtime and ultimately drive up the cost of your electric utility bill. With electric utility deregulation, more attention is now being paid to peak demand charges, power factor penalties and the added cost of harmonic distortion.

That's why we designed the Phoenix DS Clean Power AC Drive. The Phoenix DS Clean Power AC Drive uses 18 Pulse rectifications to minimize both the voltage and current harmonic distortion on the AC power line. In fact, the Phoenix DS Clean Power AC Drive meets the stringent requirements of IEEE 519 1992 without the use of any additional external filters, line reactors or drive isolation transformers. You get all the economic advantages of an AC Drive, reduced inrush current demand and improved power factor, without the harmonics.

With all these real world benefits and with new economic penalties tied to power quality, it's easy to understand why more and more people are turning to the Phoenix DS Clean Power AC Drive.



POWER QUALITY

- * **Meets IEEE 519 1992 for both voltage & current harmonic distortion**
- * **No need for external filters - no matter where the drive is placed in the plant**
- * **Eliminates the need for expensive and time consuming harmonic analysis**
- * **Avoids resonance problems associated with inefficient harmonic filters**
- * **Prevents overloading of circuit breakers and feeders**
- * **Avoids transformer overheating**
- * **Eliminates penalties for poor power factor from utility company**
- * **Can be run off motor/generator systems with near zero harmonic distortion**

THREE YEAR WARRANTY

MADE IN USA

PHOENIX DS CLEAN POWER (18 PULSE) AC DRIVE DIGITAL AC MOTOR CONTROL 7.5 TO 3,500HP

OUTSTANDING FEATURES

High Voltage Ratings Line voltages in the United States are now averaging as high as 500VAC, in Canada that figure is 600VAC. Designing a product that doesn't take this fact into consideration will result in a product that will have power bridge failures or at best, nuisance overvoltage tripping. The Phoenix is rated to handle these new voltage averages with $\pm 10\%$ to spare!

Built In Radio Frequency Filter The RFI filter, that is standard in the Phoenix, reduces noise in the radio frequency band which may be generated by the drive. The R.F.I. filter has a secondary benefit of protecting the drive from high voltage transients which occur when attached to motors with long leads. Many drive manufacturers ignore these potential problems that can cause radio communications problems in a facility and weaken the integrity of the drive.

Input Line Suppression Metal oxide varistors are included on each unit to absorb line voltage transients, not only phase to phase, but also phase to ground. Without these suppression devices the drive's power semiconductors are exposed to high potential voltages.

Short Circuit Protection If any of the output phases are shorted together (motor stator failure) or if an output phase shorts to ground, the Phoenix will safely shut down protecting itself until the short is cleared. These types of conditions often occur during installation when a power lead is nicked and shorts to conduit.

Smart Power Start We have developed a unique starting feature in the Phoenix, which produces a higher starting torque in the motor, then that achieved by line starting. By independently finding the right voltage and frequency to apply to the motor, the Phoenix creates more starting torque than most Vector controlled drives! This is essential with loads that require high starting torque and high inertia loads.

50°C Ambient Temperature We know there are many places in North America where the ambient temperature can be very high during the summer months. Many products coming from overseas, however, have lowered their cost by providing a product that can only handle an ambient temperature of 104°F(40°C) in an enclosure. The Phoenix has been designed to handle the heat with a rating of 122°F(50°C) in a Nema type 1 enclosure.

Additional Standard Features:

- * Backlit Keypad with Configurable Display
- * Motor Overload Protection - Meets NEC 430
- * Coast to Rest or Ramp Stop
- * Isolated Control Circuitry
- * Non-Volatile Parameter Storage
- * User Security Code
- * Programmable Auto Restart
- * S Curve Accel / Decel

- * Eight Preset Speeds
- * Eight Accel / Decel Rates
- * Two Timers with Alarms for Customer Use
- * Two Threshold Detectors for Customer Use
- * Set point Control with PID
- * DC Injection Braking
- * Critical Speed Rejection
- * Kw / Kwh Metering

ENGINEERING DATA

Electrical Specifications:

Rated Input Voltage:	200-250Vac, 380-500Vac, 500-600Vac -15% of minimum, +10% of maximum.
Frequency Tolerance:	45-65 Hz
Number of Phases:	3
Displacement Power Factor:	.95 or greater
Efficiency:	97% or greater at rated current
Max. Short Circuit Current Rating:	200,000A rms symmetrical, 600 volts (when used with AC input line fuses specified in tables 1-1 to 1-3 of the Instruction Manual).

Control Specifications:

Control Method:	Sine coded PWM with programmable carrier. Space Vector control.
Output Voltage:	0 to rated voltage.
Output Frequency Range:	0 to 600 Hz.
Frequency accuracy:	Analog reference: 0.1% of max frequency. Digital reference: 0.01% of max frequency.
Frequency resolution:	Analog reference: 0.06Hz at 60Hz. Digital reference: 0.001Hz at 60Hz.
Accel/Decel:	0.1 to 3276 sec.
Drive overload:	At Constant Torque: 150% of drive rated output for 1 minute. At Variable Torque: 120% of drive rated output for 1 minute.
Inverse Time Overload:	Programmable motor overload protection to comply with N.E.C. Article 430.
Current limit:	Proactive current limit programmable in % of motor rated current.
Braking torque:	Approximately 20%.
Maximum connected motor:	2 times rated drive horsepower.

Environmental Specifications:

Ambient Temperature:	-10°C to 50°C (14°F to 122°F) Nema type 1 enclosed.
Storage Temperature:	-40°C to 70°C (-40°F to 158°F) Nema type 1 enclosed.
Altitude:	Sea level to 3300 Feet [1000m] without derating.
Humidity:	95% relative humidity non-condensing.
Vibration:	9.8m/sec ² (1.0G) peak.
Immunity:	IEEE C62.41-1991 Category B (Formerly known as IEEE 587) EN50082-2 (Generic Immunity Standard).
Input R.F.I. Filter:	Standard on all models.

Physical attributes:

Mounting:	Though hole or panel mount for size 0 to size 3 drives. Size 4 drives are free standing enclosure.
Nema Rating:	Type 1 (IP20) as standard, Type 12 (IP54) optional.
Construction:	Steel construction (reduces E.M.I.)

Protective Features:

- Programmable speed sensitive motor overload protection to comply with UL 508C sections 43.3, 43.4 and 43.5.
- Drive overload protection to protect inverter.
- Motor stall protection at acceleration /deceleration and constant speed operation.
- Peak output current monitoring to protect against line-to-line shorts and line-to-ground shorts.
- Heatsink over-temperature monitoring.
- AC line overvoltage protection.
- DC bus over-voltage protection.

- DC bus under-voltage protection.
- Programmable stall protection.
- Internal power supply monitoring.
- AC power loss detection.
- Critical speed rejection with programmable 3 points with bandwidth to avoid mechanical resonance.
- Flycatcher "catch a spinning motor".
- Password protection to prevent parameter changes by unauthorized personnel.
- 4 to 20ma reference loss detection.
- Programmable thresholds and more.

Control I/O:

- 8 Digital Inputs: 7 user programmable inputs and 1 dedicated input for "Stop", rated for 24Vdc logic control.
- 2 Digital Outputs: 2 programmable dry contacts rated 115Vac @ 5A; 30Vdc @ 3.5A.
- 2 analog inputs: -10 to +10V (10 bits) with 75K Ω input impedance or 4-20 mA @ 500 Ω - Programmable.
- 2 analog outputs: -10 to +10V (10 bits) @ 2 mA max with output impedance = 100 Ω . - Programmable.
- 1 voltage reference: +15Vdc reference @ 10 mA max.
- 24Vdc source: Use to power operator pushbuttons and US Drives, Inc. option boards: 24Vdc @ 80 mA max.

Standard Drives Features:

- New generation IGBT.
- Nema Type 1 (IP20) as standard for all models.
- 50°C ambient with standard Nema type 1 (IP20) enclosure.
- High voltage ratings: 250Vac+10% , 500Vac+10% models and 600Vac+10% models
- Modbus RTU serial communications ready.
- Input line suppression: Metal oxide varistors for line-to-line and line-to-ground voltage surge protection.
- Built-in radio frequency filter.
- Nonvolatile parameter storage.
- All parameters are saved in EEPROM (nonvolatile).
- Auto logging fault history: ten last faults recorded in order of occurrence.
- Simple programming through the Real-time Operator module (R.O.M.) with all data entries and monitoring in engineering units with English descriptions.
- Set point Control P.I.D.
- Injection DC Braking with braking time calculated automatically by the drive.
- Critical speed rejection.
- Programmable auto restart.
- Parameter security code.
- User definable displays with programmable format and parameter scaling.
- 7 programmable digital inputs for custom setups.
- Metering: AC line voltage, motor current, motor voltage, DC Bus voltage, Kw, Kwh, running Kwh cost and more...
- 8 programmable digital preset speeds with user selectable acceleration and deceleration rates.
- M.O.P. function.
- Programmable PWM carrier frequency, fixed or variable.
- Programmable Time Based Function Generator and Programmable Threshold Detectors
- Run Time and Power on Time Countdown Timers with Alarms plus Run Time and Power on Time Totalizers
- Bi-directional auto-speed search (flycatcher) for starting into rotating loads.
- S-curve accel/decel control.
- Programmable time delay and logic functions (AND, OR, NOR) of bit parameters, digital inputs and outputs.
- Adding, subtracting, multiplying, dividing, ramping, limiting and/or filtering functions of parameters and analog inputs and outputs.
- Parameters can be displayed, routed to an analog/digital output or re-routed and used as an input parameter to control another function within the drive.
- User programmable functions and modes.
- Power loss ride through.
- Sleep mode PID.
- Pump underload and overload protection and load recovery.
- Pump backspin control.

WHAT IS INCLUDED

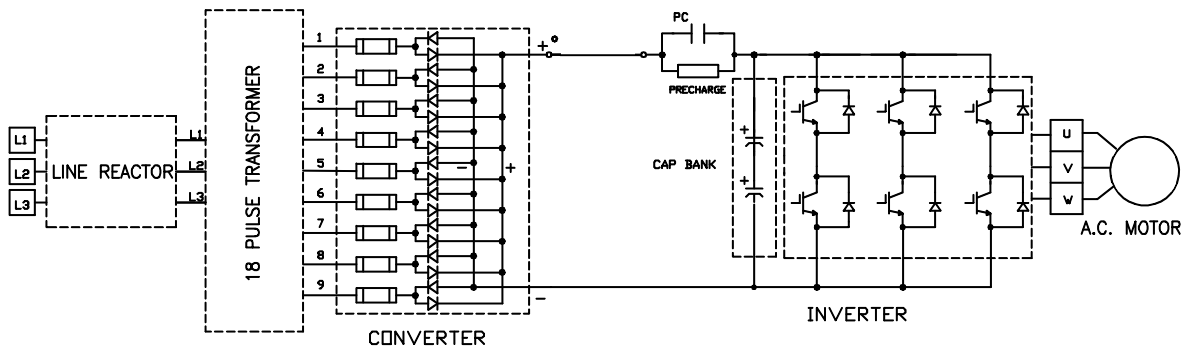

Every Phoenix DS Clean Power (18 Pulse) AC Drive Includes the Following:

- * Input AC Line Reactor (5%)
- * 18 Pulse Phase Shifting Transformer
- * 18 Pulse Diode Rectifier Bridge
- * Phoenix DS Inverter Section

COMPARISON OF DRIVE TYPES

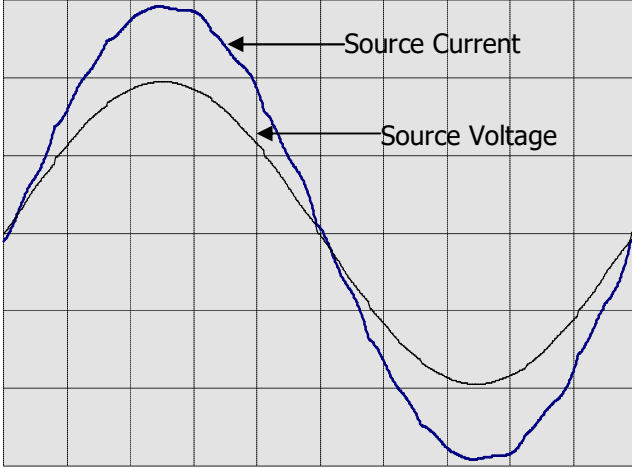

PHOENIX DS CLEAN POWER AC DRIVE

Total Harmonic Distortion
 (Voltage) = .68% (Current) = 1.71%
 Five 400Hp *Clean-Drives* (Total: 2000Hp)
 Operating from a 2500Kva Transformer with 5.75% Impedance
 Primary Voltage: 16,500Vac
 Secondary Voltage: 480Vac

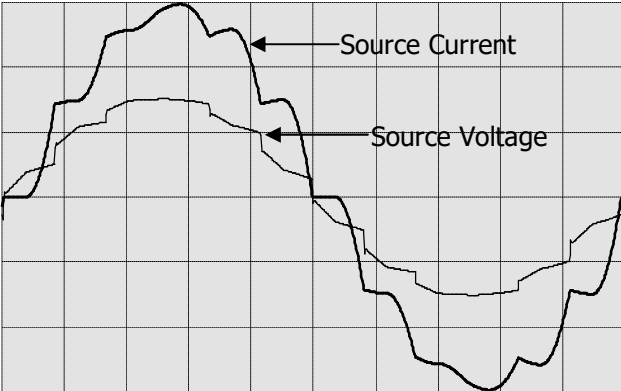

TWELVE PULSE PWM DRIVE

Total Harmonic Distortion
 (Voltage) = 6.40% (Current) = 8.71%
 Three 600Hp *Twelve-Pulse Drives* (Total: 1800Hp)
 Operating from a 2250Kva Transformer with 5.75% Impedance
 Primary Voltage: 13,500Vac
 Secondary Voltage: 480Vac

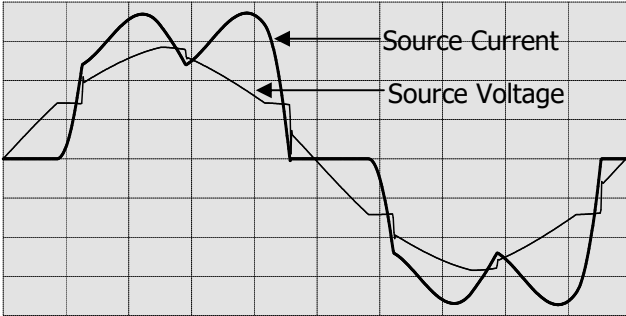

SIX PULSE PWM DRIVE

Total Harmonic Distortion
 (Voltage) = 7.42% (Current) = 29.10%
 One 1000Hp *Six-Pulse Drive*
 Operating from a 1250Kva Transformer with 5.75% Impedance
 Primary Voltage: 13,500Vac
 Secondary Voltage: 480Vac

CATALOG NUMBER EXPLANATION

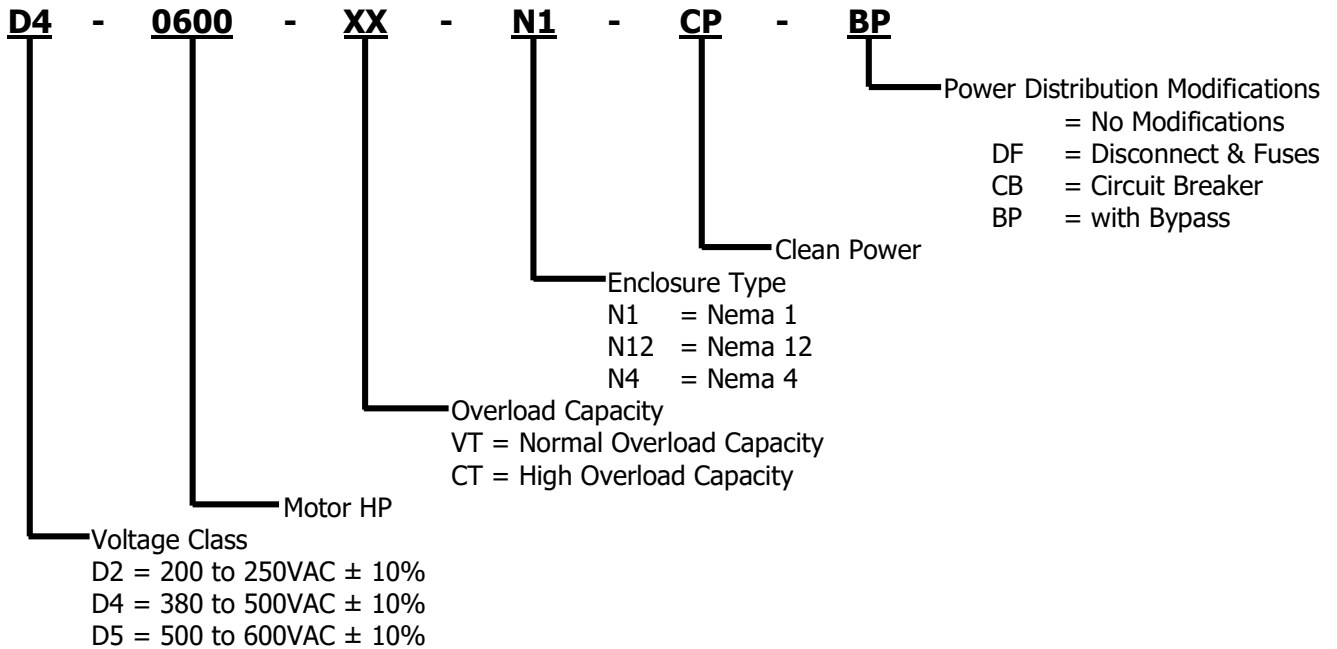

CATALOG NUMBER SELECTION / RATING TABLES

200-250VAC (-10% to +10%)							
Frame	NEMA 1 (IP20) Catalog Number ²	Motor HP ¹	Continuous ^{3,4} Output Current (Amps)	Output KVA ⁵	Input Current (Amps)	Input KVA ⁵	Maximum Recommended AC Line Fuses ⁶ (Amps)
SIZE 1	D2-0020XX-N1-CP	20	54	22	43	18	70
	D2-0025XX-N1-CP	25	68	28	54	23	90
	D2-0030XX-N1-CP	30	85	35	65	27	100
SIZE 2	D2-0040XX-N1-CP	40	104	43	87	36	150
	D2-0050XX-N1-CP	50	130	54	108	45	200
	D2-0060XX-N1-CP	60	163	68	130	54	250
	D2-0075XX-N1-CP	75	192	80	162	68	300
	D2-0100XX-N1-CP	100	248	103	217	90	300
SIZE 3	D2-0125XX-N1-CP	125	312	130	271	113	7
	D2-0150XX-N1-CP	150	360	150	325	135	7
	D2-0200XX-N1-CP	200	480	200	433	180	7
	D2-0250XX-N1-CP	250	602	250	541	225	7

¹ Horsepower rating based on 230 VAC Motors.

² "XX" = CT for High Overload Capacity Drives, "XX" = VT for Normal Overload Capacity Drives.

³ High Overload Capacity Drives (CT) produce 150% of Rated Drive Output Current for 1 minute.

⁴ Normal Overload Capacity Drives (VT) produce 120% of Rated Drive Output Current for 1 minute.

⁵ Output and Input KVA at nominal 240 VAC.

⁶ UL Class T, J and Semiconductor Fuses (preferred): Ferraz Shawmut A50Q, Bussmann FWH.

⁷ Included as standard.

CATALOG NUMBER SELECTION / RATING TABLES

380-500VAC (-10% to +10%)							
Frame	NEMA 1 (IP20) Catalog Number ²	Motor HP ¹	Continuous Output Current (Amps) ^{3,4}	Output KVA ⁵	Input Current (Amps)	Input KVA ⁵	Maximum Recommended AC Line Fuses ⁶ (Amps)
SIZE 1	D4-0040XX-N1-CP	40	52	43	43	36	70
	D4-0050XX-N1-CP	50	66	55	54	45	90
	D4-0060XX-N1-CP	60	82	68	65	54	100
SIZE 2	D4-0075XX-N1-CP	75	97	81	81	68	125
	D4-0100XX-N1-CP	100	124	103	108	90	175
	D4-0125XX-N1-CP	125	156	130	135	113	200
	D4-0150XX-N1-CP	150	180	150	162	135	250
	D4-0200XX-N1-CP	200	240	200	217	180	350
SIZE 3	D4-0250XX-N1-CP	250	302	251	271	225	?
	D4-0300XX-N1-CP	300	361	300	325	270	?
	D4-0350XX-N1-CP	350	414	344	379	315	?
	D4-0400XX-N1-CP	400	477	397	433	360	?
	D4-0450XX-N1-CP	450	540	449	487	405	?
SIZE 4	D4-0500XX-N1-CP	500	600	499	541	450	?
	D4-0600XX-N1-CP	600	720	599	650	540	?
	D4-0700XX-N1-CP	700	840	698	758	630	?
	D4-0800XX-N1-CP	800	960	798	866	720	?
	D4-0900XX-N1-CP	900	1080	898	974	810	?
	D4-1000XX-N1-CP	1000	1200	998	1083	900	?

Consult Factory for Higher HP Drives

¹ Horsepower rating based on 460 VAC Motors.

² "XX" = CT for High Overload Capacity Drives, "XX" = VT for Normal Overload Capacity Drives.

³ High Overload Capacity Drives (CT) produce 150% of Rated Drive Output Current for 1 minute.

⁴ Normal Overload Capacity Drives (VT) produce 120% of Rated Drive Output Current for 1 minute.

⁵ Output and Input KVA at nominal 480 VAC.

⁶ UL Class T and Semiconductor Fuses (preferred): Ferraz Shawmut A50Q, Bussmann FWH.

⁷ Included as standard.

CATALOG NUMBER SELECTION / RATING TABLES

500-600VAC (-10% to +10%)							
Frame	NEMA 1 (IP20) Catalog Number ²	Motor HP ¹	Continuous Output Current (Amps) ^{3,4}	Output KVA ⁵	Input Current (Amps)	Input KVA ⁵	Maximum Recommended AC Line Fuses ⁶ (Amps)
SIZE 1	D5-0040XX-N1-CP	40	41	41	35	36	60
	D5-0050XX-N1-CP	50	52	52	43	45	80
	D5-0060XX-N1-CP	60	65	65	52	54	90
	D5-0075XX-N1-CP	75	78	78	65	68	100
	D5-0100XX-N1-CP	100	99	99	87	90	150
SIZE 2	D5-0125XX-N1-CP	125	125	124	108	113	175
	D5-0150XX-N1-CP	150	157	156	136	135	200
	D5-0200XX-N1-CP	200	192	191	173	180	300
	D5-0250XX-N1-CP	250	242	241	217	225	7
	D5-0300XX-N1-CP	300	289	288	260	270	7
SIZE 3	D5-0350XX-N1-CP	350	336	335	303	315	7
	D5-0400XX-N1-CP	400	382	380	346	360	7
	D5-0450XX-N1-CP	450	432	430	390	405	7
	D5-0500XX-N1-CP	500	472	470	433	450	7
	D5-0600XX-N1-CP	600	576	574	520	540	7
	D5-0700XX-N1-CP	700	672	669	606	630	7
	D5-0800XX-N1-CP	800	768	765	693	720	7
SIZE 4	D5-0900XX-N1-CP	900	864	860	779	810	7
	D5-1000XX-N1-CP	1000	960	956	866	900	7
	D5-1200XX-N1-CP	1200	1152	1195	1039	1080	7
	Consult Factory for Higher HP Drives						

¹ Horsepower rating based on 575 VAC Motors.

² "XX" = CT for High Overload Capacity Drives, "XX" = VT for Normal Overload Capacity Drives.

³ High Overload Capacity Drives (CT) produce 150% of Rated Drive Output Current for 1 minute.

⁴ Normal Overload Capacity Drives (VT) produce 120% of Rated Drive Output Current for 1 minute.

⁵ Output and Input KVA at nominal 600 VAC.

⁶ UL Class T, CC and Semiconductor Fuses (preferred): Ferraz Shawmut A70Q, Bussmann FWP.

⁷ Included as standard.

Dimensions - Nema 1 Enclosed

Input Voltage	Motor HP	VFD Only		VFD with Disconnect & Fuses		VFD with Bypass	
		Approximate Dimensions (HxWxD)	Figure	Approximate Dimensions (HxWxD)	Figure	Approximate Dimensions (HxWxD)	Figure
200 - 250 VAC (208/230/240)	20 - 30	60" x 24" x 24"	1	60" x 24" x 24"	1	60" x 24" x 24"	1
	40 - 100	72" x 30" x 25"	1	72" x 30" x 25"	1	72" x 30" x 25"	2
	125 - 250	72" x 72" x 30"	2	72" x 72" x 30"	2	72" x 72" x 30"	3
	Above 250	Consult Factory	-	Consult Factory	-	Consult Factory	-
380 - 500 VAC (380/400/415/480)	40 - 60	60" x 24" x 24"	1	60" x 24" x 24"	1	60" x 24" x 24"	1
	75 - 200	72" x 30" x 25"	1	72" x 30" x 25"	1	72" x 30" x 25"	2
	250 - 500	72" x 72" x 30"	2	72" x 72" x 30"	2	72" x 72" x 30"	3
	600 - 1000	84" x 118" x 30"	3	84" x 118" x 30"	3	84" x 118" x 30"	-
	Above 1000	Consult Factory	-	Consult Factory	-	Consult Factory	-
525 - 600 VAC (525/575/600)	40 - 75	60" x 24" x 24"	1	60" x 24" x 24"	1	60" x 24" x 24"	1
	100 - 200	72" x 30" x 25"	1	72" x 30" x 25"	1	72" x 30" x 25"	2
	250 - 600	72" x 72" x 30"	2	72" x 72" x 30"	2	72" x 72" x 30"	3
	700 - 1200	84" x 118" x 30"	3	84" x 118" x 30"	3	84" x 118" x 30"	-
	Above 1200	Consult Factory	-	Consult Factory	-	Consult Factory	-

Dimensions - Nema 12 Enclosed

Input Voltage	Motor HP	VFD Only		VFD with Disconnect & Fuses		VFD with Bypass	
		Approximate Dimensions (HxWxD)	Figure	Approximate Dimensions (HxWxD)	Figure	Approximate Dimensions (HxWxD)	Figure
200 - 250 VAC (208/230/240)	20 - 30	60" x 24" x 24"	1	60" x 24" x 24"	1	60" x 24" x 24"	1
	40 - 100	72" x 30" x 25"	1	72" x 30" x 25"	1	72" x 30" x 25"	2
	125 - 250	72" x 72" x 30"	2	72" x 72" x 30"	2	72" x 72" x 30"	3
	Above 250	Consult Factory	-	Consult Factory	-	Consult Factory	-
380 - 500 VAC (380/400/415/480)	40 - 60	60" x 24" x 24"	1	60" x 24" x 24"	1	60" x 24" x 24"	1
	75 - 200	72" x 30" x 25"	1	72" x 30" x 25"	1	72" x 30" x 25"	2
	250 - 500	72" x 72" x 30"	2	72" x 72" x 30"	2	72" x 72" x 30"	3
	600 - 1000	84" x 118" x 30"	3	84" x 118" x 30"	3	84" x 118" x 30"	-
	Above 1000	Consult Factory	-	Consult Factory	-	Consult Factory	-
525 - 600 VAC (525/575/600)	40 - 75	60" x 24" x 24"	1	60" x 24" x 24"	1	60" x 24" x 24"	1
	100 - 200	72" x 30" x 25"	1	72" x 30" x 25"	1	72" x 30" x 25"	2
	250 - 600	72" x 72" x 30"	2	72" x 72" x 30"	2	72" x 72" x 30"	3
	700 - 1200	84" x 118" x 30"	3	84" x 118" x 30"	3	84" x 118" x 30"	-
	Above 1200	Consult Factory	-	Consult Factory	-	Consult Factory	-

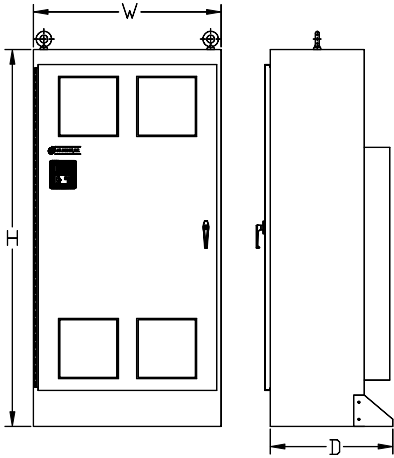

Figure 1

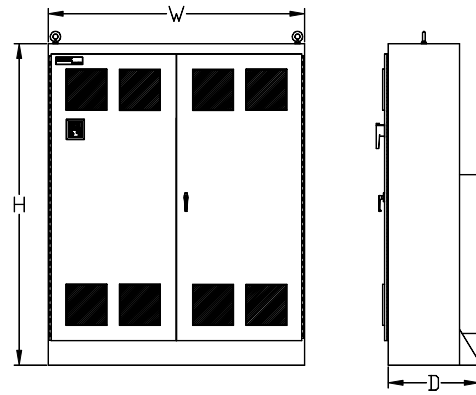

Figure 2

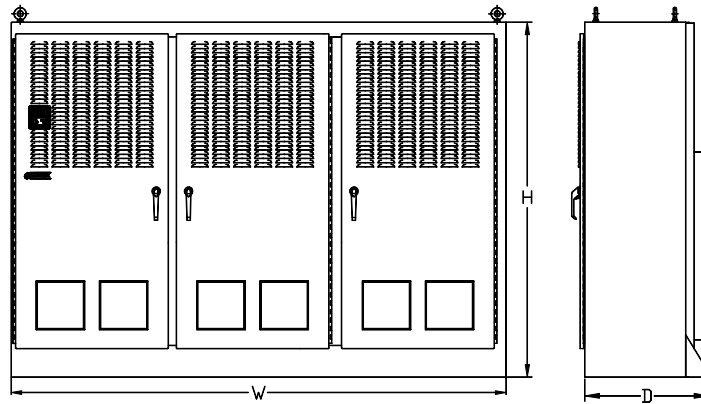

Figure 3

PHOENIX OPTIONS

OPTION DESCRIPTION	CATALOG NUMBER
<p>Isolated 4-20 MA Process Signal Card: The card can be used as both Input and Output to provide Signal Isolation.</p> <p>Board Input: 0-10 VDC Adjustments: Span, Zero Board Output: 4-20 ma or 0-10 VDC (Isolated) Required Power Supply: 120 VDC, 100MA Maximum (Typically customer supplied) Note: Output Signal will be isolated from drive common if customer provides their own 24 VDC isolated supply Availability: Factory Installed or Kit Form Special Note: Consult factory if this modification must be mounted and wired inside a Size 0 Phoenix DS or Phoenix ES Control Enclosure. An Oversized Enclosure or an Enclosure Extension may be required to accommodate this option.</p>	3000-4041-120
<p>115VAC Operator (Digital Input) Interface Card: The Phoenix AC Drive is designed to accept contact closures and/or logic inputs at a 24 VDC level. If the Drive will be operated using remote Pushbuttons and Selector Switches powered at the 115 VAC level, this card should be used. This card accepts 120 VAC logic level input signals and converts them to 24 VDC logic level inputs.</p> <p>Required Power Supply: 120VAC, 30VA minimum (Typically customer supplied) Availability: Factory Installed or Kit Form Special Note: Consult factory if this modification must be mounted and wired inside a Size 0 Phoenix DS or Phoenix ES Control Enclosure. An Oversized Enclosure or an Enclosure Extension may be required to accommodate this option. See page ES10 for Enclosure Options.</p>	3000-4050
<p>Isolated Communications Card (RS-232/422/485, Modbus RTU): This Communications Option Card allows the Phoenix DS or ES AC Drive to communicate via RS-232/422/485 Serial Communications. The standard Phoenix Protocol is Modbus RTU. Modbus RTU is a simple and common serial communication link. Each communication link can handle 32 devices with an address range from 1 to 247. For easy networking, a removable screw terminal connector is provided. Operational commands and drive parameters are accessible via Modbus RTU protocol.</p> <p>Availability: Factory Installed or Kit Form Special Note: Only one Communications Card (ie. 3000-4235-1, 3000-4135-2 or 3000-4145) may be added per Drive.</p>	3000-4135
<p>Encoder Feedback Card: The Encoder Feedback Card allows the Phoenix ES AC Drive to operate as a Closed Loop AC Vector Drive with Speed Regulation accuracy to 0.01%. In Closed Loop Mode, extremely accurate control of Motor Speed and Motor Torque is possible at speeds to Zero RPM. The Encoder Feedback Card includes an Isolated Encoder Power Supply and includes repeated Encoder Differential Outputs for customer use.</p> <p>Required Power Supply: None - Powered by Drive. Encoder Requirements: Dual Channel, Quadrature Type, with Differential Line Driven Output. Encoder Power Supply: +12 VDC or +5 VDC at 200 ma. Required Input Signals: A+, A-, B+, B-, 5 to 12 VDC at 20 ma maximum. Optional Input Signals: A+, Z-. Output Signals: A+, A-, B+, B-, Z+, Z-, 5 VDC at 20 ma maximum. Maximum Encoder Frequency: 300 KHz Availability: Factory Installed or Kit Form - Only Available on the Phoenix ES</p>	3000-4140-1
<p>Second Encoder Input Card: The Second Encoder Input Card allows the Phoenix ES AC Drive to accept two different Encoder input signals. Typically one Encoder input signal is used for Closed Loop Speed Control while the second Encoder input provides the drive reference signal (a pulse train input). Precise synchronization (digital locking) of two independent machines is possible.</p> <p>Required Power Supply: None - Powered by Drive. Encoder Requirements: Dual Channel, Quadrature Type, with Differential Line Driven Output. Encoder Power Supply: +12 VDC or +5 VDC at 200 ma. Required Input Signals: A+, A-, B+, B-, 5 to 12 VDC at 20 ma maximum. Optional Input Signals: A+, Z-. Output Signals: A+, A-, B+, B-, Z+, Z-, 5 VDC at 20 ma maximum. Maximum Encoder Frequency: 300 KHz Availability: Factory Installed or Kit Form - Only Available on the Phoenix ES</p>	3000-4160
<p>I/O Expansion Board: Phoenix DS and Phoenix ES AC Drives include 8 Digital Inputs, 2 Digital Outputs, 2 Analog Inputs and 2 Analog Outputs as Standard. If additional Inputs and Outputs are required, the Phoenix DS/ES I/O Expansion Board may be added. With the addition of the Phoenix DS/ES I/O Expansion Board, the drive can support up to 8 Digital Inputs, 7 Digital Outputs, 3 Analog Inputs and 3 Analog Outputs. The Phoenix DS/ES I/O Expansion Board is fully configurable. You may add up to 5 Digital Outputs, 1 Analog Input and 1 Analog Output.</p> <p>Availability: Factory Installed or Kit Form</p>	3000-4150
<p>Removable USB/RS-485 Isolated Communications Interface with Cable: This Removable Communications Interface with Cable option allows the Phoenix DS or ES AC Drive to communicate via RS-485 with a Laptop. This option is very useful to field program Drives using a Laptop with Drivemaster. The interface cable is 8 feet with a standard USB connector.</p> <p>Availability: Kit Form</p>	3000-4225-USB
<p>HOA Switch: A factory installed Hand-Off-Auto switch allows the operator to select how the drive will be operated. In "Hand" Mode the drive is operated using local Start and Stop Pushbuttons or the Keypad Pushbuttons and a local Speed Reference signal. In "Auto" Mode the drive is controlled by remote Start and Stop Pushbuttons or contacts and remote Speed Reference signal.</p> <p>Availability: Factory Installed Only Included as Standard on Phoenix AC Drives with Bypass Special Note: Consult Factory if this modification must be mounted and wired inside a Size 0 Phoenix DS or Phoenix ES Control Enclosure. An Oversized Enclosure or an Enclosure Extension may be required to accommodate this option.</p>	PDS-HOA-SW

OPTION DESCRIPTION	CATALOG NUMBER
<p>Local/Remote Switch: A factory installed Local-Remote switch allows the operator to select where the logic signals that control the drive will come from. In "Local" Mode, they will come from Local Start/Stop Pushbuttons or from the Pushbuttons on the drive Keypad. In "Remote" Mode they will come from remote Start and Stop Pushbuttons or contacts.</p> <p>Availability: Factory Installed Only Special Note: Consult Factory if this modification must be mounted and wired inside a Size 0 Phoenix DS or Phoenix ES Control Enclosure. An Oversized Enclosure or an Enclosure Extension may be required to accommodate this option.</p>	PDS-LR-SW
<p>Auto/Manual Switch: A factory installed Auto-Manual switch allows the operator to select where the Speed Reference Signal will come from. In "Auto" Mode, the reference signal will come from the remote source. In "Manual" Mode the reference will come from a local Speed Potentiometer or the Drive Keypad.</p> <p>Availability: Factory Installed Only Special Note: Consult Factory if this modification must be mounted and wired inside a Size 0 Phoenix DS or Phoenix ES Control Enclosure. An Oversized Enclosure or an Enclosure Extension may be required to accommodate this option.</p>	PDS-AM-SW
<p>Speed Potentiometer: A factory installed Speed Potentiometer gives local speed control by potentiometer.</p> <p>Availability: Factory Installed Only Special Note: Consult Factory if this modification must be mounted and wired inside a Size 0 Phoenix DS or Phoenix ES Control Enclosure. An Oversized Enclosure or an Enclosure Extension may be required to accommodate this option.</p>	PDS-POT
<p>Automatic-Bypass Adder for Size 0 Drive with Manual Bypass: This factory installed option can be added to a Phoenix AC Drive with Manual Contactor Bypass to automatically transfer to Bypass Mode when a fault is detected.</p> <p>Availability: Factory Installed Only</p>	PDS-ABP0
<p>Automatic-Bypass Adder for Size 1 Drive with Manual Bypass: This factory installed option can be added to a Phoenix AC Drive with Manual Contactor Bypass to automatically transfer to Bypass Mode when a fault is detected.</p> <p>Availability: Factory Installed Only</p>	PDS-ABP1
<p>Automatic-Bypass Adder for Size 2 Drive with Manual Bypass: This factory installed option can be added to a Phoenix AC Drive with Manual Contactor Bypass to automatically transfer to Bypass Mode when a fault is detected.</p> <p>Availability: Factory Installed Only</p>	PDS-ABP2
<p>Automatic-Bypass Adder for Size 3 Drive with Manual Bypass: This factory installed option can be added to a Phoenix AC Drive with Manual Contactor Bypass to automatically transfer to Bypass Mode when a fault is detected.</p> <p>Availability: Factory Installed Only</p>	PDS-ABP3
<p>Bezel Assembly for Keypad (ROM): This metal frame covers the cutout you would normally make in the door of an enclosure to remotely mount the Realtime-Operator-Module (ROM).</p> <p>Availability: Kit Form Only</p>	PDS-BZL
<p>Ribbon Cable Extender for Keypad (ROM) - 6 Feet: This cable allows the user to remove the Phoenix Realtime-Operator-Module from its normal location on the face of the drive module and remotely mount it up to six feet away. This cable is typically used when the drive module is mounted inside another enclosure (Nema 12 or Nema 4) and the Keypad must be mounted on the door of the enclosure.</p> <p>Availability: Kit Form Only</p>	PDS-CBL-6
<p>Remote Keypad (ROM) Kit: Bezel with 10 foot Ribbon Cable Extender.</p> <p>Availability: Kit Form Only</p>	PDS-BZL-CBL-10
<p>Remote Keypad (ROM) Kit: Bezel with 20 foot Ribbon Cable Extender.</p> <p>Availability: Kit Form Only</p>	PDS-BZL-CBL-20

Communications Options

US Drives, Inc. offers many different Communication Cards to interface our AC Drives to a wide variety of industrial networks.

USB/RS-485 Communications Interface with Cable – All Phoenix DS and Phoenix ES AC Drives include a built in RS-232 serial communications port. A Removable USB/RS-485 Communications Cable with Isolator (P/N 3000-4226-USB) is available to allow the direct connection of a laptop or other PC to the drive. All drive parameters are accessible via Modbus RTU protocol.

Modbus RTU RS-232/422/485 - Modbus RTU is a simple, easy to use serial communications protocol. This plug-in Communications Card (P/N 3000-4135) mounts directly on the drive and connects to the customer's network via a removable screw terminal connector. The hardware can be configured for RS-232, RS-422 or RS-485 communications at data rates of 4,800 baud, 9,600 baud and 19,200 baud. When configured for RS-485 multi-drop, up to 32 devices can be connected on the network. All drive parameters, are accessible via Modbus RTU protocol.

Ethernet/Modbus TCP - Ethernet/Modbus TCP extends commercial off-the-shelf Ethernet to the factory floor while making use of the popular Modbus protocol. Modbus TCP is the most commonly used protocol for Industrial Ethernet applications. This Communications allows one or more drives to be connected to any Ethernet network using standard Ethernet cables and an RJ45 type Ethernet connector. Up to 32 drives can be connected to an Ethernet network using one Ethernet/Modbus TCP Communications Card. A Modbus RTU RS-232/422/485 Communications Card (P/N 3000-4135) is also required for each drive. All drive parameters, are accessible via the Ethernet using Modbus TCP protocol.

Ethernet/IP - Ethernet/IP extends commercial off-the-shelf Ethernet to the factory floor using the same upper-layer protocol and object model found in DeviceNet and ControlNet. This Communications Module allows one or more drives to be connected to any Ethernet network using standard Ethernet cables and an RJ45 type Ethernet connector. Up to 32 drives can be connected to an Ethernet network using one Ethernet/IP Communications Module. A Modbus RTU RS-232/422/485 Communications Card (P/N 3000-4135) is also required for each drive. All drive parameters, are accessible via the Ethernet using Ethernet/IP protocol. This Communications Module complies with the Ethernet/IP specification.

DeviceNet - DeviceNet serves as a communications link between industrial controllers and I/O devices including drives. This Communications Module allows one or more drives to be connected to any DeviceNet network using a standard DeviceNet connector. Up to 32 drives can be connected to a DeviceNet network using one DeviceNet Communications Module. A Modbus RTU RS-232/422/485 Communications Card (P/N 3000-4135) is also required for each drive. All drive parameters, can be accessed via the DeviceNet network. This module complies with the ODVA DeviceNet specification.

Profibus DP - Profibus is the leading industrial communication network for manufacturing automation in Europe. This Communications Module allows one or more drives to be connected to any Profibus network through a Phoenix-type connector using twisted-pair wiring. Up to 32 drives can be connected to a Profibus network using one Profibus Communications Module. A Modbus RTU RS-232/422/485 Communications Card (P/N 3000-4135) is also required for each drive. All drive parameters, can be accessed via the Profibus network using Profibus DP protocol. This module complies with standards developed by the Profibus User Organization (PNO).

Other Networks - Communications Interface Modules are also available for Modbus Plus, CANopen, Interbus, ControlNet, ProfiNet and selected other networks. Consult your US Drives, Inc. Sales Representative for details.

Drivemaster

Drivemaster is a Windows based program designed to make drive set-up, record keeping and trouble-shooting easy. Drive parameters can be extracted from a drive, reviewed, modified, printed, stored on disk, reloaded back into the same drive or copied to another drive. Data Logging and Graphing of drive parameters is also possible. Offline and Online Editing is supported. Drivemaster supports both Modbus Serial Communications and Ethernet / Modbus TCP Communications.

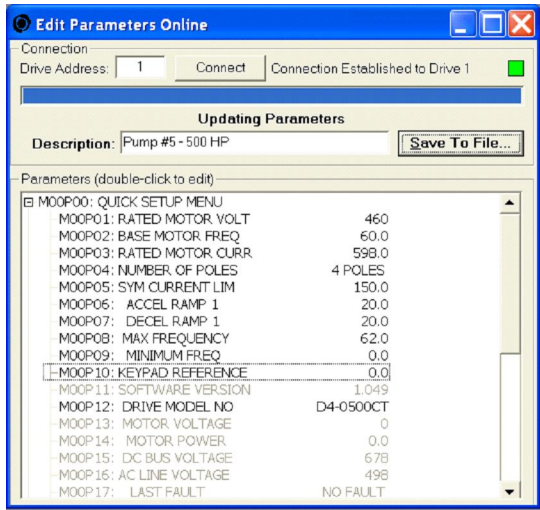

Edit and Save Drive Parameters

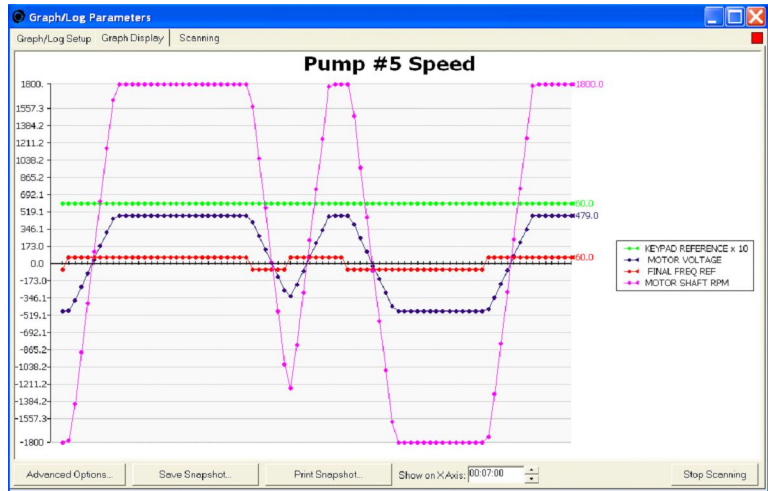

Graph

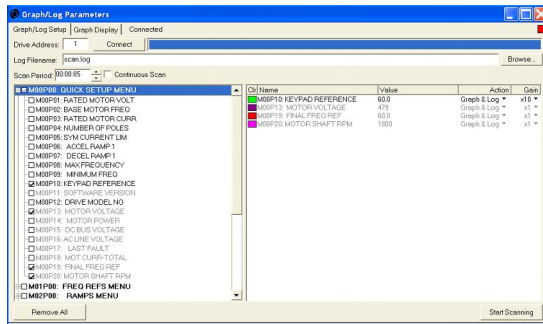

Date	Time	MOOP14	MOOP15	MOOP16	MOOP18	MOOP19	MOOP20
*** Log Opened: 13:38:20 01-27-2006							
01-27-2006	13:38:52	0.5	635	457	6.5	60.0	1800
01-27-2006	13:39:26	0.5	632	457	6.5	60.0	1800
01-27-2006	13:40:00	0.6	633	457	6.5	-60.0	-1800
01-27-2006	13:40:34	0.6	633	457	6.5	-60.0	-1800
01-27-2006	13:41:08	0.6	632	457	6.4	-60.0	-1800
01-27-2006	13:41:41	0.3	631	457	9.7	60.0	837
01-27-2006	13:42:15	0.5	634	457	6.5	60.0	1800
01-27-2006	13:42:49	0.5	631	457	6.4	60.0	1800
01-27-2006	13:43:22	0.6	633	457	7.7	-60.0	-804
01-27-2006	13:43:56	0.5	628	456	6.4	-60.0	-1800
*** Log Closed: 13:44:27 01-27-2006							
*** Log Opened: 13:29:18 02-02-2006							

Data Logging



USB/RS-485 Communications Interface with Cable

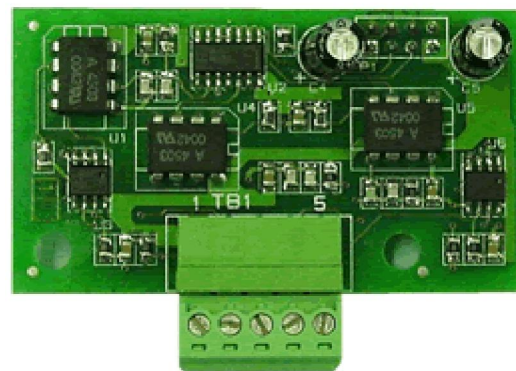

Serial Communications Card

AC Line Regenerative Module

Our AC Line Regen Module turns any PWM AC Drive into a Line Regenerative AC Drive. Excess (regenerative) energy from the AC Motor is efficiently returned to the AC Power Line, eliminating the need for expensive, bulky and inefficient braking resistors. This is especially true when continuous braking is required.



Typical Applications that require regeneration are:

- High Inertia Loads that must be stopped or slowed down quickly - Saws, Fans, Flywheels and Centrifuges.
- Unwind Stands of all types - Uncoilers, Payoffs
- Overhauling Loads - Hoists, Cranes, Downhill Conveyors and Holdback Rolls in Process Line Applications.
- Machine applications with fast cycle times that require rapid deceleration.

Our AC Line Regen Module is easy to use. There are only five wires to connect: 3 - AC Power and 2 - DC Bus.

Our AC Line Regen Modules are 99% efficient and operate at near unity power factor. Modules are easily paralleled for higher power applications.

- **Eliminates the need for energy wasting braking resistors**
- **Provides continuous regeneration on overhauling loads**
- **Instantaneous energy flow between load & utility**
- **Prevents AC Drives from overvoltage tripping**
- **Allows rapid stopping of high inertia loads**
- **Uses the latest generation of IGBT power devices**
- **Delivers substantial energy savings**
- **Phase insensitive to the AC power line**

SPECIFICATIONS AND FEATURES

Electrical Specifications:

Rated Input Voltage:	200-250Vac, 380-500Vac, 500-600Vac -10% of minimum, +10% of maximum.
Frequency Tolerance:	47-63 Hz
Number of Phases:	3
Efficiency:	99% or greater
Max. Short Circuit Current Rating:	200,000A rms symmetrical, 600 volts (when used with AC input line fuses specified in tables 1 to 3).
Noise Immunity:	IEEE C62.41-1991 Category B (Formerly known as IEEE 587) - 6000V tests EN50082-1, 2 Generic Immunity Standards IEC 1000-4-2 (IEC 801-2) IEC 1000-4-3 (IEC 801-3) IEC 1000-4-4 (IEC 801-4) IEC 1000-4-5 (IEC 801-5) IEC 1000-4-6 (IEC 801-6) IEC 1000-4-8 (IEC 801-8)

Environmental Specifications:

Ambient Temperature:	-10°C to 55°C (14°F to 131°F) Nema type 1 enclosed.
Storage Temperature:	-40°C to 70°C (-40°F to 158°F) Nema type 1 enclosed.
Altitude:	Sea level to 3000 Feet [1000m] without derating.
Humidity:	95% relative humidity non-condensing.
Vibration:	9.8m/sec ² (1.0G) peak.

Physical attributes:

Mounting:	Though hole or panel mount.
Nema Rating:	Type 1 (IP20) as standard, Type 12 (IP54) optional.
Construction:	Steel construction (reduces E.M.I.)

Control I/O:

Logic Inputs: Regenerative Module Enable
Regenerative Module Reset

Logic Output: Two Relays with Contacts Rated 115Vac @ 5Amps, 30Vac @ 3.5Amps
- Normally open contact energized when Regen is "ON"
- Normally open contact energized when "Regen Precharge" is complete.

Protective Features:

- Peak output current monitoring to protect against line-to-line shorts and line-to-ground shorts.
- Ground fault monitoring.
- Heatsink over-temperature monitoring.
- AC line & DC bus over-voltage protection.
- AC line & DC bus under-voltage protection.
- Control power supply power ride-thru.
- Internal power supply monitoring.
- AC phase loss detection.

Standard Regen Features

- Latest generation IGBT.
- Nema type 1 (IP20) as standard for all models.
- 55°C ambient with standard Nema type 1 (IP20) enclosure.
- High voltage ratings: 250Vac+10% , 500Vac+10% models and 600Vac+10% models
- Input line suppression: Metal oxide varistors for line-to-line and line-to-ground voltage surge protection.
- No programming or hardware jumper for all voltages.

Table 1
Class 200 AC Regen Models (Typical Voltage 208/230/240 VAC)

200-250VAC (-10% to +10%)							
Frame Designation	NEMA 1 (IP20) Catalog Number	Continuous DC Bus Current (Amps)	Continuous Regen Power ¹ KW	Drive HP ²	AC Current (Amps)	Maximum Recommended AC Line Fuses ³ (Amps)	Total Power Losses ⁴ (W)
SIZE 1	RG-0200-0030-N1	30	11	15	29	40	176
	RG-0200-0045-N1	45	16	20	44	60	239
	RG-0200-0060-N1	60	21	30	58	90	302
	RG-0200-0090-N1	90	32	40	85	125	428
	RG-0200-0120-N1	120	42	60	116	175	554
	RG-0200-0180-N1	180	63	75	175	250	806
SIZE 2	RG-0200-0240-N1	240	84	100	233	350	1058
	RG-0200-0300-N1	300	105	125	291	450	1300
	RG-0200-0360-N1	360	126	150	349	600	1562
SIZE 3	RG-0200-0480-N1	480	168	200	466	700	2066
	RG-0200-0540-N1	540	189	250	524	900	2318
	RG-0200-0600-N1	600	210	300	582	900	2570
	RG-0200-0720-N1	720	252	350	698	1000	3074
	RG-0200-0840-N1	840	294	400	815	1200	3578
	RG-0200-0960-N1	960	336	450	931	1200	4082
	RG-0200-1080-N1	1080	378	500	1048	1500	4586
	RG-0200-1440-N1	1440	504	700	1397	2000	6098

¹ KW based on 240Vac AC Power line.

² Drive HP ratings are calculated for 230 VAC Motors based on 100% Continuous Regeneration and 150% Regeneration for 1 Minute or Less.

Consult Factory for Module sizing when Regeneration requirements are less than or greater than these values.

³ UL Class T, High Speed/Class J and Semiconductor Fuses (preferred): Ferraz Shawmut A50P, A60X, Bussmann FWH.

⁴ Total Power Loss shown is for continuous operation at full regeneration.

Table 2
Class 400 AC Regen Models (Typical Voltage 380/415/480 VAC)

380-500VAC (-10% to +10%)							
Frame Designation	NEMA 1 (IP20) Catalog Number	Continuous DC Bus Current (Amps)	Continuous Regen Power ¹ KW	Drive HP ²	AC Current (Amps)	Maximum Recommended AC Line Fuses ³ (Amps)	Total Power Losses ⁴ (W)
SIZE 1	RG-0400-0030-N1	30	21	30	29	40	200
	RG-0400-0045-N1	45	32	40	44	60	275
	RG-0400-0060-N1	60	42	60	58	90	350
	RG-0400-0090-N1	90	63	75	85	125	500
	RG-0400-0120-N1	120	84	100	116	175	650
	RG-0400-0180-N1	180	126	150	175	250	950
SIZE 2	RG-0400-0240-N1	240	168	200	233	350	1250
	RG-0400-0300-N1	300	210	300	291	450	1525
	RG-0400-0360-N1	360	252	350	349	600	1850
SIZE 3	RG-0400-0480-N1	480	336	450	466	700	2450
	RG-0400-0540-N1	540	378	500	524	900	2750
	RG-0400-0600-N1	600	420	600	582	900	3050
	RG-0400-0720-N1	720	504	700	698	1000	3650
	RG-0400-0840-N1	840	588	800	815	1200	4250
	RG-0400-0960-N1	960	672	900	931	1200	4850
	RG-0400-1080-N1	1080	756	1000	1048	1500	5450
	RG-0400-1440-N1	1440	1008	1400	1397	2000	7250

¹ KW based on 480Vac AC Power line.

² Drive HP ratings are calculated for 460 VAC Motors based on 100% Continuous Regeneration and 150% Regeneration for 1 Minute or Less.

Consult Factory for Module sizing when Regeneration requirements are less than or greater than these values.

³ UL Class T, High Speed/Class J and Semiconductor Fuses (preferred): Ferraz Shawmut A50P, A60X, Bussmann FWH.

⁴ Total Power Loss shown is for continuous operation at full regeneration.

Table 3

Class 500 AC Regen Models (Typical Voltage 525/575/600 VAC)

525-600VAC (-10% to +10%)							
Frame Designation	NEMA 1 (IP20) Catalog Number	Continuous DC Bus Current (Amps)	Continuous Regen Power ¹ KW	Drive HP ²	AC Current (Amps)	Maximum Recommended AC Line Fuses ³ (Amps)	Total Power Losses ⁴ (W)
SIZE 1	RG-0500-0030-N1	30	26	30	29	40	236
	RG-0500-0045-N1	45	39	50	44	60	329
	RG-0500-0060-N1	60	53	75	58	90	422
	RG-0500-0090-N1	90	79	100	85	125	608
	RG-0500-0120-N1	120	105	150	116	175	794
SIZE 2	RG-0500-0180-N1	180	158	200	175	250	1166
	RG-0500-0240-N1	240	210	250	233	350	1538
SIZE 2	RG-0500-0300-N1	300	263	350	291	450	1900
	RG-0500-0360-N1	360	315	400	349	600	2282
SIZE 3	RG-0500-0480-N1	480	420	500	466	700	3026
	RG-0500-0540-N1	540	473	600	524	900	3390
	RG-0500-0600-N1	600	525	700	582	900	3770
	RG-0500-0720-N1	720	630	800	698	1000	4514
	RG-0500-0840-N1	840	735	900	815	1200	5250
	RG-0500-0960-N1	960	840	1000	931	1200	6002
	RG-0500-1080-N1	1080	945	1300	1048	1500	6746
	RG-0500-1440-N1	1440	1260	1750	1397	2000	8978

¹ KW based on 600Vac AC Power line.

² Drive HP ratings are calculated for 575 VAC Motors based on 100% Continuous Regeneration and 150% Regeneration for 1 Minute or Less.

Consult Factory for Module sizing when Regeneration requirements are less than or greater than these values.

³ UL Class T, High Speed/Class J and Semiconductor Fuses (preferred): Ferraz Shawmut A60X, A70P, Bussmann FWP.

⁴ Total Power Loss shown is for continuous operation at full regeneration.

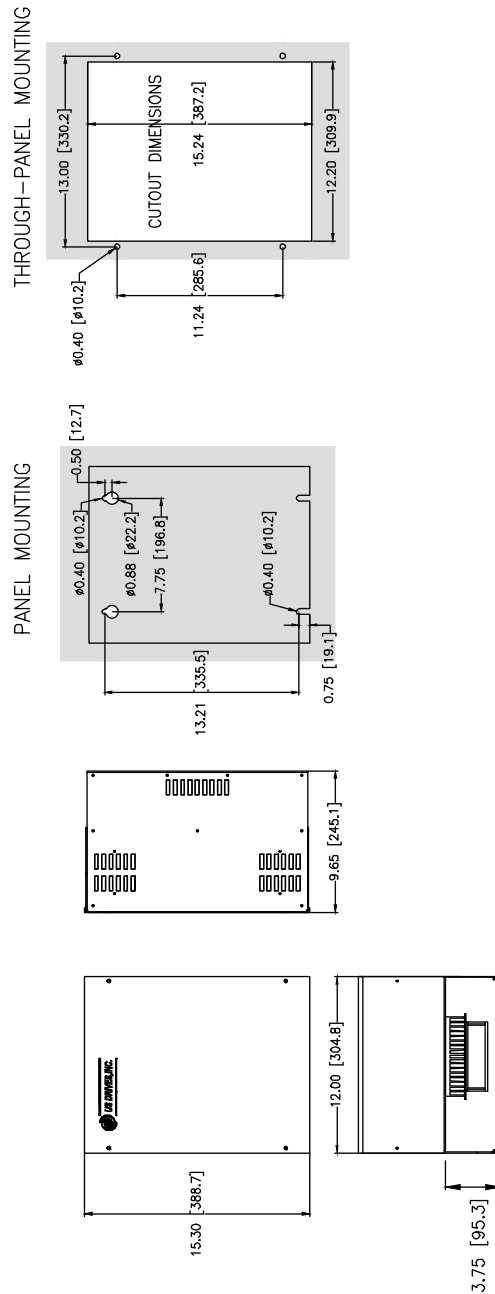

Approximate Weight: 35 Lbs. [16 Kgs]

Notes:

- Top and bottom endplates are removable to gain access inside the drive and to punch holes for conduits.
- Endplates must be removed from the drive before drilling and punching holes to avoid metal dust inside the drive enclosure. Failure to do so will cause damage to the drive.
- For through-panel mounting, customer is to seal for gap on all side of cutout. Provided by customer, aluminum angle 1" x 1" x 0.050" can be used to attach to all sides of drive to help seal and secure the drive.

Figure 2
AC Regen Mounting Information:
Size 1 (Nema Type 1)

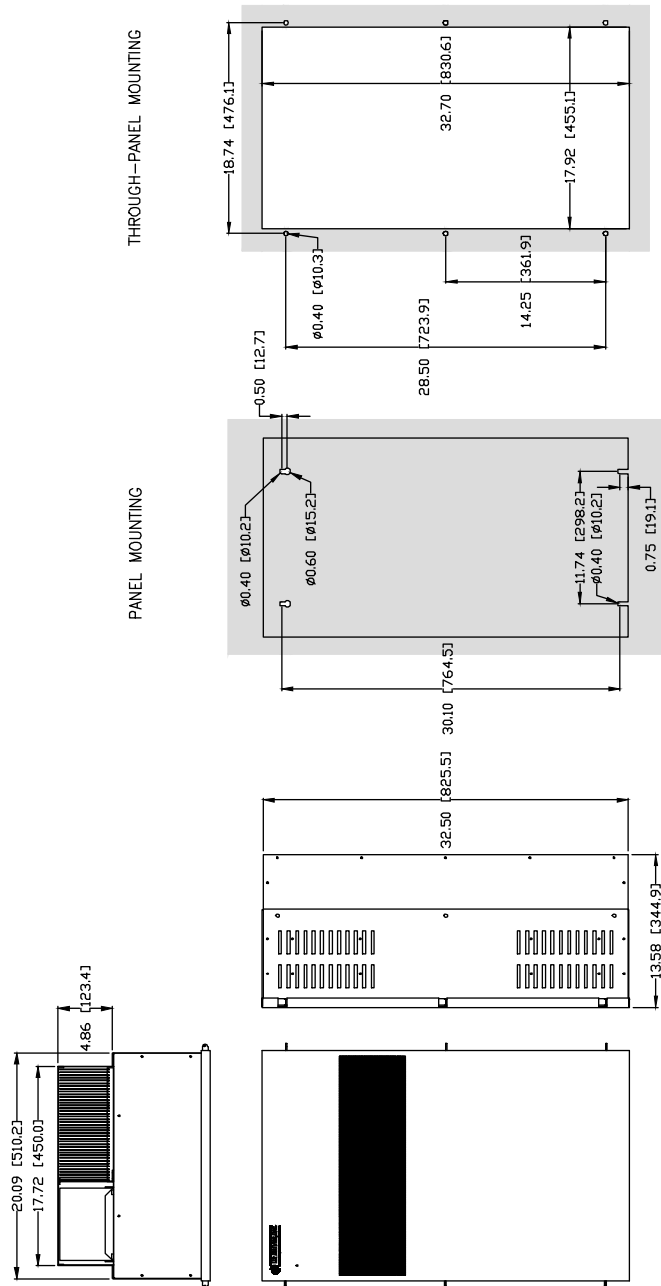

Approximate Weight: 150 Lbs. [68 Kgs]

Notes:

- Top and bottom endplates are removable to gain access inside the drive and to punch holes for conduits.
- Endplates must be removed from the drive before drilling and punching holes to avoid metal dust inside the drive enclosure. Failure to do so will cause damage to the drive.
- For through-panel mounting, customer is to seal for gap on all side of cutout. Provided by customer, aluminum angle 1" x 1" x 0.050" can be used to attach to all sides of drive to help seal and secure the drive.

Figure 2-2a
AC Regen Mounting Information:
Size 2 (Nema Type 1)

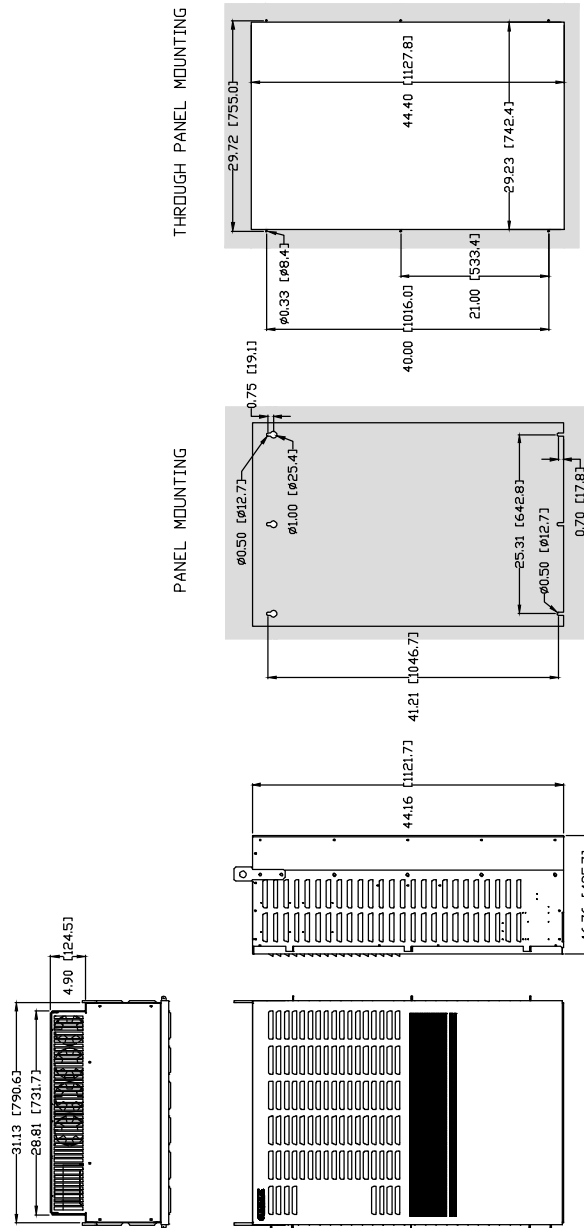

Approximate Weight: 450 Lbs. [204 Kgs]

Notes:

- Top and bottom endplates are removable to gain access inside the drive and to punch holes for conduits.
- Endplates must be removed from the drive before drilling and punching holes to avoid metal dust inside the drive enclosure. Failure to do so will cause damage to the drive.
- For through-panel mounting, customer is to seal for gap on all side of cutout. Provided by customer, aluminum angle 1" x 1" x 0.050" can be used to attach to all sides of drive to help seal and secure the drive.
- Size 3 enclosure can also be free-standing with optional floor stand kit from US Drives, Inc.

**Figure 2-2b
AC Regen Mounting Information:
Size 3 (Nema Type 1)**

Regenerative DC Common Bus Supply

The Regenerative DC Common Bus Supply supplies both motoring and regenerative current to the DC bus of one or more AC drives without the need of rectifier front end in each AC drive. When the overall power requirements of the attached common DC bus drives require motoring power, energy flows from the utility to the common DC bus. When the overall power requirements of the attached common DC bus drives require regenerative power, energy flows from the common DC bus to the utility.



Typical Applications that require regeneration are:

- High Inertia Loads that must be stopped or slowed down quickly - Saws, Fans, Flywheels and Centrifuges.
- Unwind Stands of all types - Uncoilers, Payoffs
- Overhauling Loads - Hoists, Cranes, Downhill Conveyors and Holdback Rolls in Process Line Applications.
- Machine applications with fast cycle times that require rapid deceleration.

Our Regenerative DC Common DC Bus Supply Module is easy to use. There are only five wires to connect: 3 - AC Power and 2 - DC Bus.

Our Regenerative DC Common Supply Modules are 99% efficient and operate at near unity power factor. Modules are easily paralleled for higher power applications.

- **Eliminates the need for energy wasting braking resistors**
- **Provides continuous regeneration on overhauling loads**
- **Instantaneous energy flow between load & utility**
- **Prevents AC Drives from overvoltage tripping**
- **Allows rapid stopping of high inertia loads**
- **Uses the latest generation of IGBT power devices**
- **Delivers substantial energy savings**
- **Phase insensitive to the AC power line**



REGEN DC COMMON BUS SUPPLY

SPECIFICATIONS AND FEATURES

Electrical Specifications:

Rated Input Voltage:	200-250Vac, 380-500Vac, 500-600Vac -10% of minimum, +10% of maximum.
Frequency Tolerance:	47-63 Hz
Number of Phases:	3
Efficiency:	99% or greater
Max. Short Circuit Current Rating:	200,000A rms symmetrical, 600 volts (when used with AC input line fuses specified in tables 1 to 3).
Noise Immunity:	IEEE C62.41-1991 Category B (Formerly known as IEEE 587) - 6000V tests EN50082-1, 2 Generic Immunity Standards IEC 1000-4-2 (IEC 801-2) IEC 1000-4-3 (IEC 801-3) IEC 1000-4-4 (IEC 801-4) IEC 1000-4-5 (IEC 801-5) IEC 1000-4-6 (IEC 801-6) IEC 1000-4-8 (IEC 801-8)

Environmental Specifications:

Ambient Temperature:	-10°C to 55°C (14°F to 131°F) Nema type 1 enclosed.
Storage Temperature:	-40°C to 70°C (-40°F to 158°F) Nema type 1 enclosed.
Altitude:	Sea level to 3000 Feet [1000m] without derating.
Humidity:	95% relative humidity non-condensing.
Vibration:	9.8m/sec ² (1.0G) peak.

Physical attributes:

Mounting:	Though hole or panel mount.
Nema Rating:	Type 1 (IP20) as standard, Type 12 (IP54) optional.
Construction:	Steel construction (reduces E.M.I.)

Control I/O:

Logic Inputs: Regenerative Module Enable
Regenerative Module Reset

Logic Outputs: Two Relays with Contacts Rated 115Vac @ 5Amps, 30Vac @ 3.5Amps
- Normally open contact energized when Regen is "ON"
- Normally open contact energized when "Regen Precharge" is complete.

Protective Features:

- Peak output current monitoring to protect against line-to-line shorts and line-to-ground shorts.
- Ground fault monitoring.
- Heatsink over-temperature monitoring.
- AC line & DC bus over-voltage protection.
- AC line & DC bus under-voltage protection.
- Control power supply power ride-thru.
- Internal power supply monitoring.
- AC phase loss detection.

Standard Regen Features

- Latest generation IGBT.
- Nema type 1 (IP20) as standard for all models.
- 55°C ambient with standard Nema type 1 (IP20) enclosure.
- High voltage ratings: 250Vac+10% , 500Vac+10% models and 600Vac+10% models
- Input line suppression: Metal oxide varistors for line-to-line and line-to-ground voltage surge protection.
- No programming or hardware jumper for all voltages.

Table 1
Class 200 Regenerative DC Common Bus Supply Models
(Typical Voltage 208/230/240 VAC)

200-250VAC (-10% to +10%)							
Frame Designation	NEMA 1 (IP20) Catalog Number	Drive HP ²	Continuous Regen DC Bus Current (Amps)	Continuous Motoring DC Bus Current (Amps)	AC Current (Amps)	Maximum Recommended AC Line Fuses ³ (Amps)	Total Power Losses ⁴ (W)
SIZE 1	RGB-0200-0030-N1	15	30	37	39	60	176
	RGB-0200-0045-N1	20	45	49	50	70	239
	RGB-0200-0060-N1	30	60	73	63	90	302
SIZE 1A	RGB-0200-0090-N1	40	90	98	97	125	428
	RGB-0200-0120-N1	60	120	146	143	200	554
SIZE 2	RGB-0200-0180-N1	75	180	183	179	250	806
	RGB-0200-0240-N1	100	240	244	231	350	1058
	RGB-0200-0300-N1	125	300	305	290	400	1300
	RGB-0200-0360-N1	150	360	366	335	500	1562
SIZE 3	RGB-0200-0480-N1	200	480	488	446	600	2066
	RGB-0200-0540-N1	250	540	610	560	800	2318
	RGB-0200-0600-N1	300	600	732	670	900	2570
	RGB-0200-0720-N1	350	720	854	781	1000	3074
	RGB-0200-0840-N1	400	840	976	893	1200	3578
	RGB-0200-0960-N1	450	960	1098	1004	1500	4082
	RGB-0200-1080-N1	500	1080	1220	1116	1500	4586

¹ KW based on 240Vac AC Power line.

² Drive HP ratings are calculated for 230 VAC Motors based on 100% Continuous Regeneration and 150% Regeneration for 1 Minute or Less.

Consult Factory for Module sizing when Regeneration requirements are less than or greater than these values.

³ Semiconductor Fuses: Ferraz Shawmut A50P, A60X, Bussmann FWH.

⁴ Total Power Loss shown is for continuous operation at full regeneration.

Table 2
Class 400 Regenerative DC Common Bus Supply Models
(Typical Voltage 380/415/480 VAC)

380-500VAC (-10% to +10%)							
Frame Designation	NEMA 1 (IP20) Catalog Number	Drive HP ²	Continuous Regen DC Bus Current (Amps)	Continuous Motoring DC Bus Current (Amps)	AC Current (Amps)	Maximum Recommended AC Line Fuses ³ (Amps)	Total Power Losses ⁴ (W)
SIZE 1	RGB-0400-0030-N1	30	30	37	37	50	200
	RGB-0400-0045-N1	40	45	49	48	70	275
	RGB-0400-0060-N1	60	60	73	72	100	350
SIZE 1A	RGB-0400-0090-N1	75	90	91	89	125	500
	RGB-0400-0120-N1	100	120	122	115	175	650
SIZE 2	RGB-0400-0180-N1	150	180	183	167	250	950
	RGB-0400-0240-N1	200	240	244	223	350	1250
	RGB-0400-0300-N1	300	300	366	336	450	1525
	RGB-0400-0360-N1	350	360	427	385	600	1850
SIZE 3	RGB-0400-0480-N1	450	480	549	502	800	2450
	RGB-0400-0540-N1	500	540	610	558	800	2750
	RGB-0400-0600-N1	600	600	732	670	900	3050
	RGB-0400-0720-N1	700	720	854	781	1000	3650
	RGB-0400-0840-N1	800	840	976	893	1200	4250
	RGB-0400-0960-N1	900	960	1098	1004	1500	4850
	RGB-0400-1080-N1	1000	1080	1220	1116	1500	5450

¹ KW based on 480Vac AC Power line.

² Drive HP ratings are calculated for 460 VAC Motors based on 100% Continuous Regeneration and 150% Regeneration for 1 Minute or Less.

Consult Factory for Module sizing when Regeneration requirements are less than or greater than these values.

³ Semiconductor Fuses: Ferraz Shawmut A50P, A60X, Bussmann FWH.

⁴ Total Power Loss shown is for continuous operation at full regeneration.

Table 3
Class 500 Regenerative DC Common Bus Supply Models
(Typical Voltage 525/575/600 VAC)

525-600VAC (-10% to +10%)							
Frame Designation	NEMA 1 (IP20) Catalog Number	Drive HP ²	Continuous Regen DC Bus Current (Amps)	Continuous Motoring DC Bus Current (Amps)	AC Current (Amps)	Maximum Recommended AC Line Fuses ³ (Amps)	Total Power Losses ⁴ (W)
SIZE 1	RGB-0500-0030-N1	30	30	32	35	40	236
	RGB-0500-0045-N1	50	45	49	48	70	329
	RGB-0500-0060-N1	75	60	73	72	100	422
SIZE 1A	RGB-0500-0090-N1	100	90	98	92	125	608
	RGB-0500-0120-N1	125	120	122	116	175	794
SIZE 2	RGB-0500-0180-N1	200	180	195	179	250	1166
	RGB-0500-0240-N1	250	240	244	225	350	1538
	RGB-0500-0300-N1	350	300	342	312	450	1900
	RGB-0500-0360-N1	400	360	390	355	600	2282
SIZE 3	RGB-0500-0480-N1	500	480	488	439	700	3026
	RGB-0500-0540-N1	600	540	586	536	800	3390
	RGB-0500-0600-N1	700	600	683	625	900	3770
	RGB-0500-0720-N1	800	720	781	714	1000	4514
	RGB-0500-0840-N1	900	840	878	804	1200	5250
	RGB-0500-0960-N1	1000	960	976	893	1200	6002
	RGB-0500-1080-N1	1300	1080	1269	1161	1500	6746

¹ KW based on 600Vac AC Power line.

² Drive HP ratings are calculated for 575 VAC Motors based on 100% Continuous Regeneration and 150% Regeneration for 1 Minute or Less. Consult Factory for Module sizing when Regeneration requirements are less than or greater than these values.

³ UL Class T, High Speed/Class J and Semiconductor Fuses (preferred): Ferraz Shawmut A60X, A70P, Bussmann FWP.

⁴ Total Power Loss shown is for continuous operation at full regeneration.

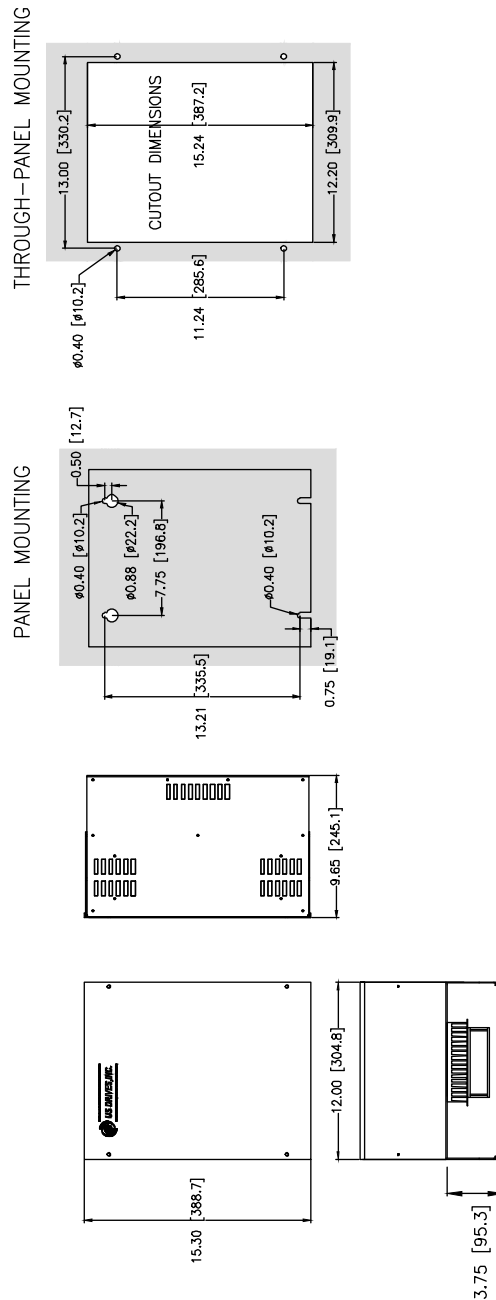

Approximate Weight: 35 Lbs. [16 Kgs]

Notes:

- Top and bottom endplates are removable to gain access inside the drive and to punch holes for conduits.
- Endplates must be removed from the drive before drilling and punching holes to avoid metal dust inside the drive enclosure. Failure to do so will cause damage to the drive.
- For through-panel mounting, customer is to seal for gap on all side of cutout. Provided by customer, aluminum angle 1" x 1" x 0.050" can be used to attach to all sides of drive to help seal and secure the drive.

Figure 2
AC Regen Mounting Information:
Size 1 (Nema Type 1)

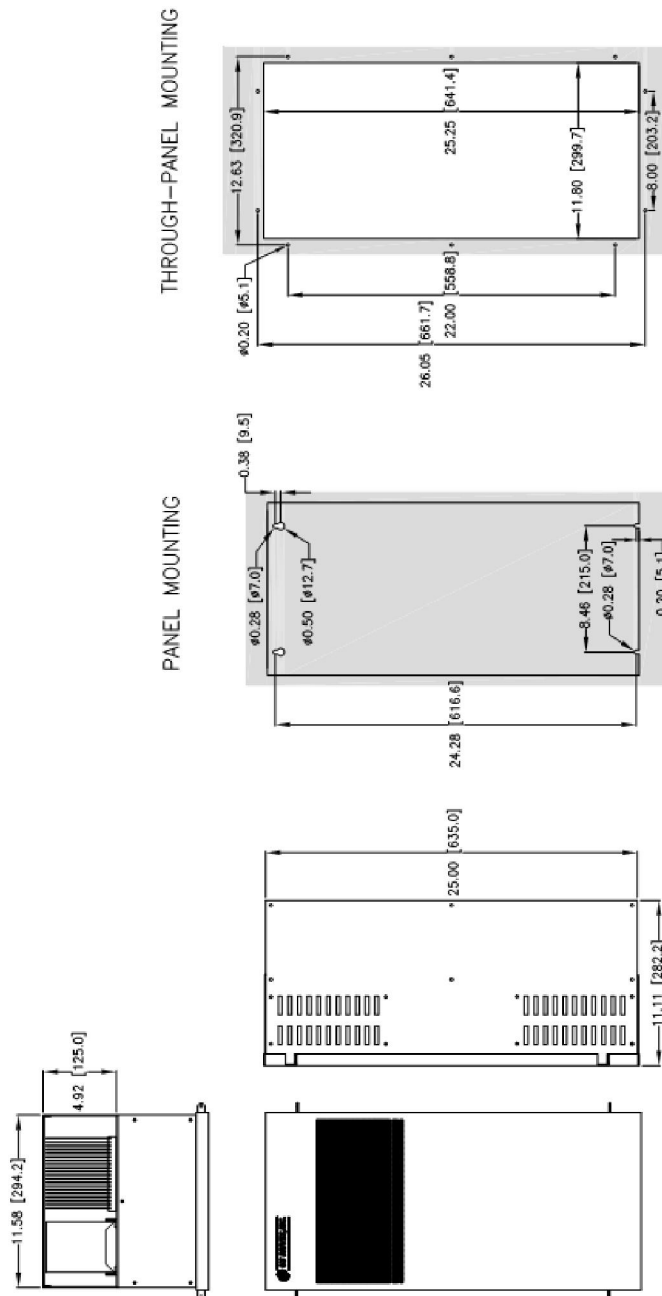

Approximate Weight: 75 Lbs. [34 Kgs]

Notes:

- Top and bottom endplates are removable to gain access inside the drive and to punch holes for conduits.
- Endplates must be removed from the drive before drilling and punching holes to avoid metal dust inside the drive enclosure. Failure to do so will cause damage to the drive.
- For through-panel mounting, customer is to seal for gap on all side of cutout. Provided by customer, aluminum angle 1" x 1" x 0.050" can be used to attach to all sides of drive to help seal and secure the drive.

Figure 2-1
AC Regen Mounting Information:
Size 1A (Nema Type 1)

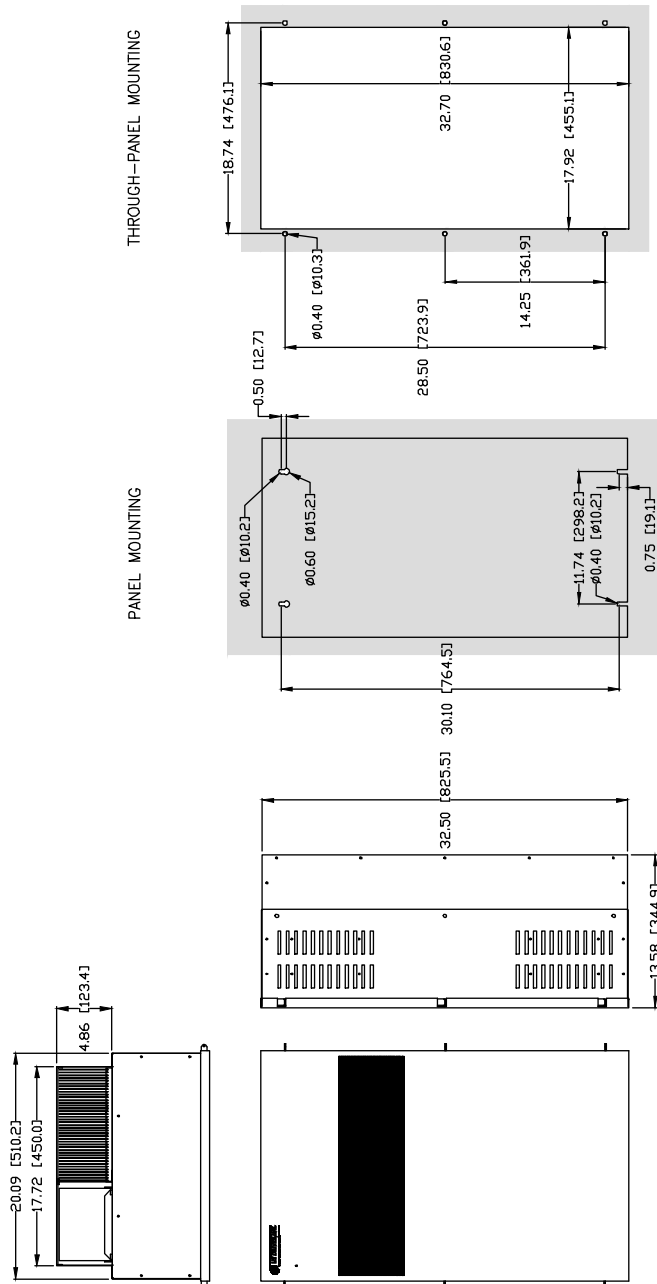

Approximate Weight: 150 Lbs. [68 Kgs]

Notes:

- Top and bottom endplates are removable to gain access inside the drive and to punch holes for conduits.
- Endplates must be removed from the drive before drilling and punching holes to avoid metal dust inside the drive enclosure. Failure to do so will cause damage to the drive.
- For through-panel mounting, customer is to seal for gap on all side of cutout. Provided by customer, aluminum angle 1" x 1" x 0.050" can be used to attach to all sides of drive to help seal and secure the drive.

**Figure 2-2a
AC Regen Mounting Information:
Size 2 (Nema Type 1)**

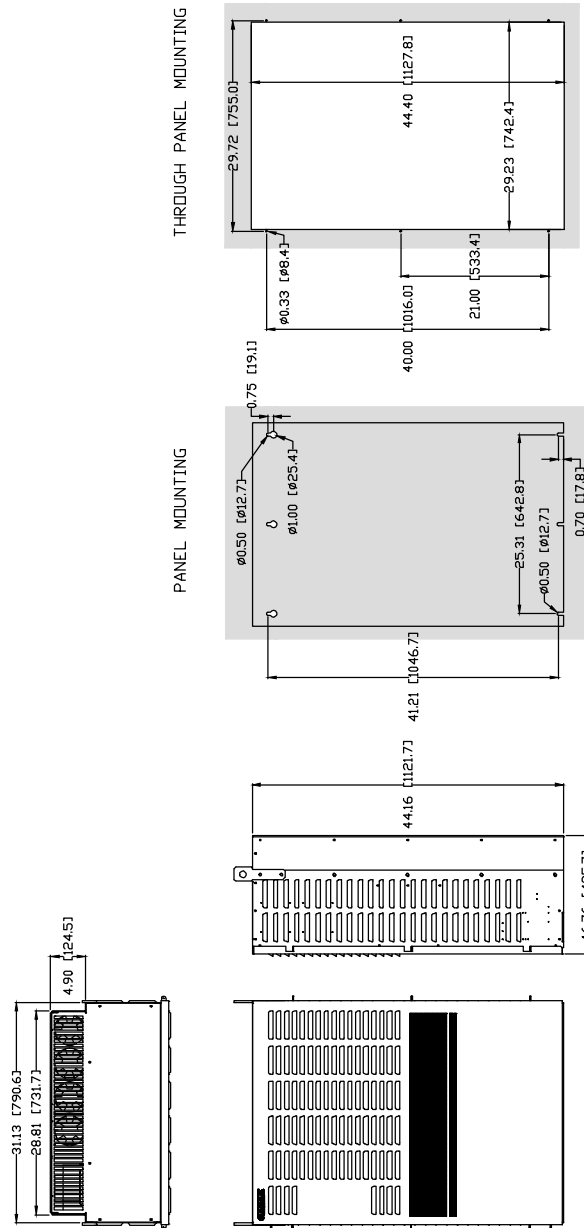

Approximate Weight: 450 Lbs. [204 Kgs]

Notes:

- Top and bottom endplates are removable to gain access inside the drive and to punch holes for conduits.
- Endplates must be removed from the drive before drilling and punching holes to avoid metal dust inside the drive enclosure. Failure to do so will cause damage to the drive.
- For through-panel mounting, customer is to seal for gap on all side of cutout. Provided by customer, aluminum angle 1" x 1" x 0.050" can be used to attach to all sides of drive to help seal and secure the drive.
- Size 3 enclosure can also be free-standing with optional floor stand kit from US Drives, Inc.

**Figure 2-2b
AC Regen Mounting Information:
Size 3 (Nema Type 1)**

TO BUILDING
GROUND OR
GROUND GRID/ROD

SHIELD IF NEEDED

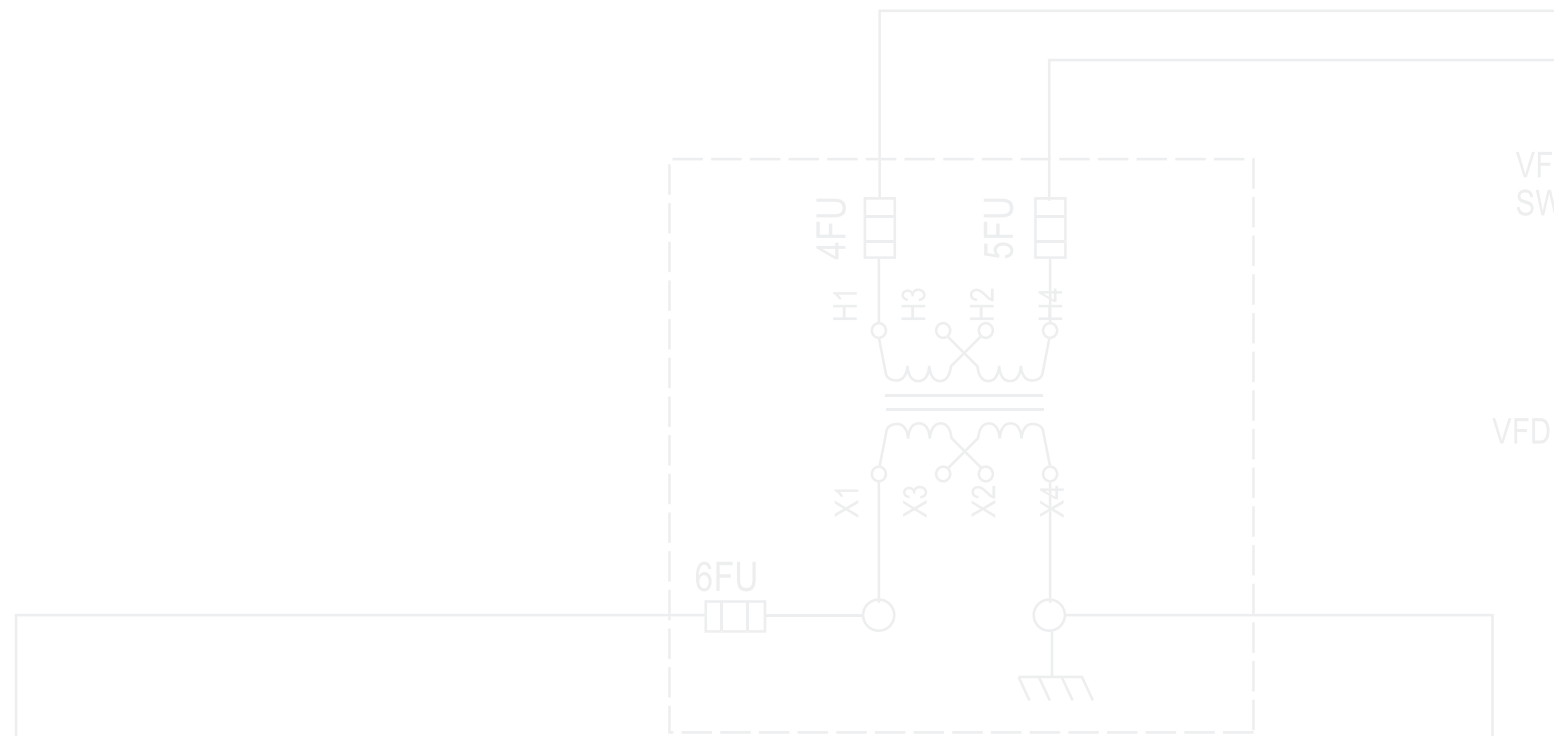

VFD SW

VFD

POWER ON



VFD MODE



CUSTOMER
INTERLOCK

VFD OFF BYP



US DRIVES, INC.

US Drives, Inc.
PO Box 281
2221 Niagara Falls Boulevard
Niagara Falls NY 14304-0281
P: 716.731.1606

BYF



24



16

17

(AUX)