

Phoenix DS Clean Power (18 Pulse) AC Drive

Poor power quality can be costly. Nonlinear loads, including AC Drives, introduce undesirable harmonic currents into the power system that can damage equipment, increase downtime and ultimately drive up the cost of your electric utility bill. With electric utility deregulation, more attention is now being paid to peak demand charges, power factor penalties and the added cost of harmonic distortion.

That's why we designed the Phoenix DS Clean Power AC Drive. The Phoenix DS Clean Power AC Drive uses 18 Pulse rectifications to minimize both the voltage and current harmonic distortion on the AC power line. In fact, the Phoenix DS Clean Power AC Drive meets the stringent requirements of IEEE 519 1992 without the use of any additional external filters, line reactors or drive isolation transformers. You get all the economic advantages of an AC Drive, reduced inrush current demand and improved power factor, without the harmonics.

With all these real world benefits and with new economic penalties tied to power quality, it's easy to understand why more and more people are turning to the Phoenix DS Clean Power AC Drive.



POWER QUALITY

- * **Meets IEEE 519 1992 for both voltage & current harmonic distortion**
- * **No need for external filters - no matter where the drive is placed in the plant**
- * **Eliminates the need for expensive and time consuming harmonic analysis**
- * **Avoids resonance problems associated with inefficient harmonic filters**
- * **Prevents overloading of circuit breakers and feeders**
- * **Avoids transformer overheating**
- * **Eliminates penalties for poor power factor from utility company**
- * **Can be run off motor/generator systems with near zero harmonic distortion**

THREE YEAR WARRANTY

MADE IN USA

PHOENIX DS CLEAN POWER (18 PULSE) AC DRIVE DIGITAL AC MOTOR CONTROL 7.5 TO 3,500HP

OUTSTANDING FEATURES

High Voltage Ratings Line voltages in the United States are now averaging as high as 500VAC, in Canada that figure is 600VAC. Designing a product that doesn't take this fact into consideration will result in a product that will have power bridge failures or at best, nuisance overvoltage tripping. The Phoenix is rated to handle these new voltage averages with $\pm 10\%$ to spare!

Built In Radio Frequency Filter The RFI filter, that is standard in the Phoenix, reduces noise in the radio frequency band which may be generated by the drive. The R.F.I. filter has a secondary benefit of protecting the drive from high voltage transients which occur when attached to motors with long leads. Many drive manufacturers ignore these potential problems that can cause radio communications problems in a facility and weaken the integrity of the drive.

Input Line Suppression Metal oxide varistors are included on each unit to absorb line voltage transients, not only phase to phase, but also phase to ground. Without these suppression devices the drive's power semiconductors are exposed to high potential voltages.

Short Circuit Protection If any of the output phases are shorted together (motor stator failure) or if an output phase shorts to ground, the Phoenix will safely shut down protecting itself until the short is cleared. These types of conditions often occur during installation when a power lead is nicked and shorts to conduit.

Smart Power Start We have developed a unique starting feature in the Phoenix, which produces a higher starting torque in the motor, then that achieved by line starting. By independently finding the right voltage and frequency to apply to the motor, the Phoenix creates more starting torque than most Vector controlled drives! This is essential with loads that require high starting torque and high inertia loads.

50°C Ambient Temperature We know there are many places in North America where the ambient temperature can be very high during the summer months. Many products coming from overseas, however, have lowered their cost by providing a product that can only handle an ambient temperature of 104°F(40°C) in an enclosure. The Phoenix has been designed to handle the heat with a rating of 122°F(50°C) in a Nema type 1 enclosure.

Additional Standard Features:

- * Backlit Keypad with Configurable Display
- * Motor Overload Protection - Meets NEC 430
- * Coast to Rest or Ramp Stop
- * Isolated Control Circuitry
- * Non-Volatile Parameter Storage
- * User Security Code
- * Programmable Auto Restart
- * S Curve Accel / Decel

- * Eight Preset Speeds
- * Eight Accel / Decel Rates
- * Two Timers with Alarms for Customer Use
- * Two Threshold Detectors for Customer Use
- * Set point Control with PID
- * DC Injection Braking
- * Critical Speed Rejection
- * Kw / Kwh Metering

ENGINEERING DATA

Electrical Specifications:

Rated Input Voltage:	200-250Vac, 380-500Vac, 500-600Vac -15% of minimum, +10% of maximum.
Frequency Tolerance:	45-65 Hz
Number of Phases:	3
Displacement Power Factor:	.95 or greater
Efficiency:	97% or greater at rated current
Max. Short Circuit Current Rating:	200,000A rms symmetrical, 600 volts (when used with AC input line fuses specified in tables 1-1 to 1-3 of the Instruction Manual).

Control Specifications:

Control Method:	Sine coded PWM with programmable carrier. Space Vector control.
Output Voltage:	0 to rated voltage.
Output Frequency Range:	0 to 600 Hz.
Frequency accuracy:	Analog reference: 0.1% of max frequency. Digital reference: 0.01% of max frequency.
Frequency resolution:	Analog reference: 0.06Hz at 60Hz. Digital reference: 0.001Hz at 60Hz.
Accel/Decel:	0.1 to 3276 sec.
Drive overload:	At Constant Torque: 150% of drive rated output for 1 minute. At Variable Torque: 120% of drive rated output for 1 minute.
Inverse Time Overload:	Programmable motor overload protection to comply with N.E.C. Article 430.
Current limit:	Proactive current limit programmable in % of motor rated current.
Braking torque:	Approximately 20%.
Maximum connected motor:	2 times rated drive horsepower.

Environmental Specifications:

Ambient Temperature:	-10°C to 50°C (14°F to 122°F) Nema type 1 enclosed.
Storage Temperature:	-40°C to 70°C (-40°F to 158°F) Nema type 1 enclosed.
Altitude:	Sea level to 3300 Feet [1000m] without derating.
Humidity:	95% relative humidity non-condensing.
Vibration:	9.8m/sec ² (1.0G) peak.
Immunity:	IEEE C62.41-1991 Category B (Formerly known as IEEE 587) EN50082-2 (Generic Immunity Standard).
Input R.F.I. Filter:	Standard on all models.

Physical attributes:

Mounting:	Though hole or panel mount for size 0 to size 3 drives. Size 4 drives are free standing enclosure.
Nema Rating:	Type 1 (IP20) as standard, Type 12 (IP54) optional.
Construction:	Steel construction (reduces E.M.I.)

Protective Features:

- Programmable speed sensitive motor overload protection to comply with UL 508C sections 43.3, 43.4 and 43.5.
- Drive overload protection to protect inverter.
- Motor stall protection at acceleration /deceleration and constant speed operation.
- Peak output current monitoring to protect against line-to-line shorts and line-to-ground shorts.
- Heatsink over-temperature monitoring.
- AC line overvoltage protection.
- DC bus over-voltage protection.

- DC bus under-voltage protection.
- Programmable stall protection.
- Internal power supply monitoring.
- AC power loss detection.
- Critical speed rejection with programmable 3 points with bandwidth to avoid mechanical resonance.
- Flycatcher "catch a spinning motor".
- Password protection to prevent parameter changes by unauthorized personnel.
- 4 to 20ma reference loss detection.
- Programmable thresholds and more.

Control I/O:

- 8 Digital Inputs: 7 user programmable inputs and 1 dedicated input for "Stop", rated for 24Vdc logic control.
- 2 Digital Outputs: 2 programmable dry contacts rated 115Vac @ 5A; 30Vdc @ 3.5A.
- 2 analog inputs: -10 to +10V (10 bits) with 75K Ω input impedance or 4-20 mA @ 500 Ω - Programmable.
- 2 analog outputs: -10 to +10V (10 bits) @ 2 mA max with output impedance = 100 Ω . - Programmable.
- 1 voltage reference: +15Vdc reference @ 10 mA max.
- 24Vdc source: Use to power operator pushbuttons and US Drives, Inc. option boards: 24Vdc @ 80 mA max.

Standard Drives Features:

- New generation IGBT.
- Nema Type 1 (IP20) as standard for all models.
- 50°C ambient with standard Nema type 1 (IP20) enclosure.
- High voltage ratings: 250Vac+10% , 500Vac+10% models and 600Vac+10% models
- Modbus RTU serial communications ready.
- Input line suppression: Metal oxide varistors for line-to-line and line-to-ground voltage surge protection.
- Built-in radio frequency filter.
- Nonvolatile parameter storage.
- All parameters are saved in EEPROM (nonvolatile).
- Auto logging fault history: ten last faults recorded in order of occurrence.
- Simple programming through the Real-time Operator module (R.O.M.) with all data entries and monitoring in engineering units with English descriptions.
- Set point Control P.I.D.
- Injection DC Braking with braking time calculated automatically by the drive.
- Critical speed rejection.
- Programmable auto restart.
- Parameter security code.
- User definable displays with programmable format and parameter scaling.
- 7 programmable digital inputs for custom setups.
- Metering: AC line voltage, motor current, motor voltage, DC Bus voltage, Kw, Kwh, running Kwh cost and more...
- 8 programmable digital preset speeds with user selectable acceleration and deceleration rates.
- M.O.P. function.
- Programmable PWM carrier frequency, fixed or variable.
- Programmable Time Based Function Generator and Programmable Threshold Detectors
- Run Time and Power on Time Countdown Timers with Alarms plus Run Time and Power on Time Totalizers
- Bi-directional auto-speed search (flycatcher) for starting into rotating loads.
- S-curve accel/decel control.
- Programmable time delay and logic functions (AND, OR, NOR) of bit parameters, digital inputs and outputs.
- Adding, subtracting, multiplying, dividing, ramping, limiting and/or filtering functions of parameters and analog inputs and outputs.
- Parameters can be displayed, routed to an analog/digital output or re-routed and used as an input parameter to control another function within the drive.
- User programmable functions and modes.
- Power loss ride through.
- Sleep mode PID.
- Pump underload and overload protection and load recovery.
- Pump backspin control.

WHAT IS INCLUDED

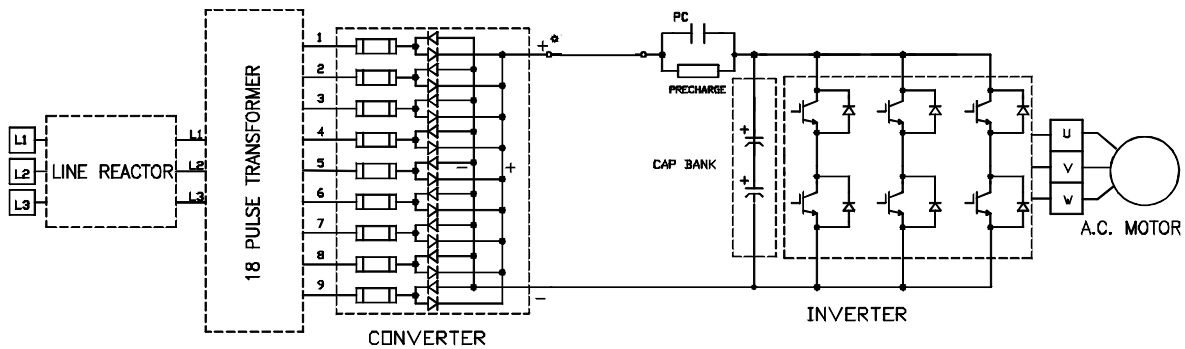

Every Phoenix DS Clean Power (18 Pulse) AC Drive Includes the Following:

- * Input AC Line Reactor (5%)
- * 18 Pulse Phase Shifting Transformer
- * 18 Pulse Diode Rectifier Bridge
- * Phoenix DS Inverter Section

COMPARISON OF DRIVE TYPES

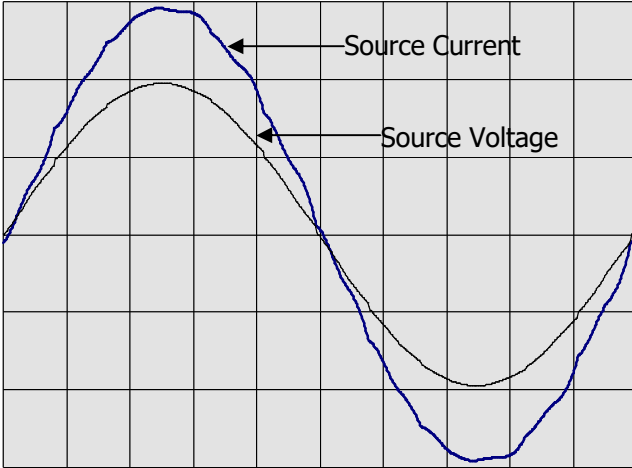

PHOENIX DS CLEAN POWER AC DRIVE

Total Harmonic Distortion
(Voltage) = .68% (Current) = 1.71%
Five 400Hp *Clean-Drives* (Total: 2000Hp)
Operating from a 2500Kva Transformer with 5.75% Impedance
Primary Voltage: 16,500Vac
Secondary Voltage: 480Vac

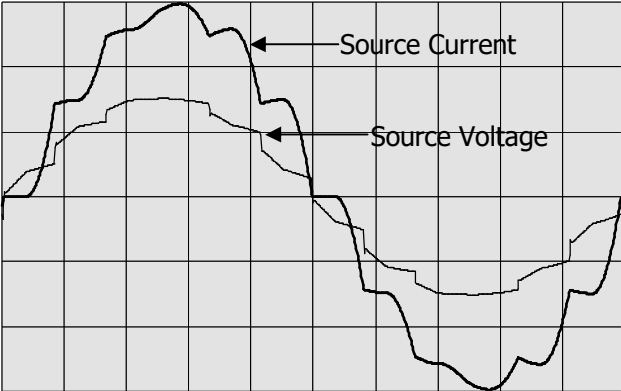

TWELVE PULSE PWM DRIVE

Total Harmonic Distortion
(Voltage) = 6.40% (Current) = 8.71%
Three 600Hp *Twelve-Pulse Drives* (Total: 1800Hp)
Operating from a 2250Kva Transformer with 5.75% Impedance
Primary Voltage: 13,500Vac
Secondary Voltage: 480Vac

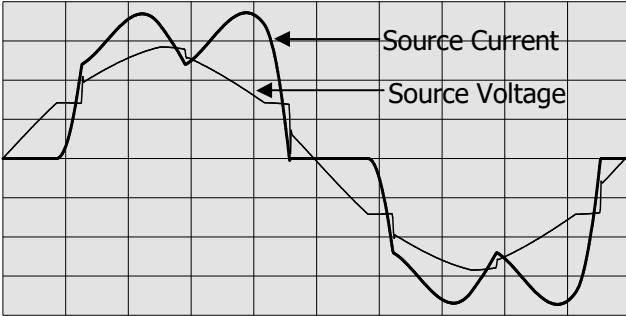

SIX PULSE PWM DRIVE

Total Harmonic Distortion
(Voltage) = 7.42% (Current) = 29.10%
One 1000Hp *Six-Pulse Drive*
Operating from a 1250Kva Transformer with 5.75% Impedance
Primary Voltage: 13,500Vac
Secondary Voltage: 480Vac

CATALOG NUMBER EXPLANATION

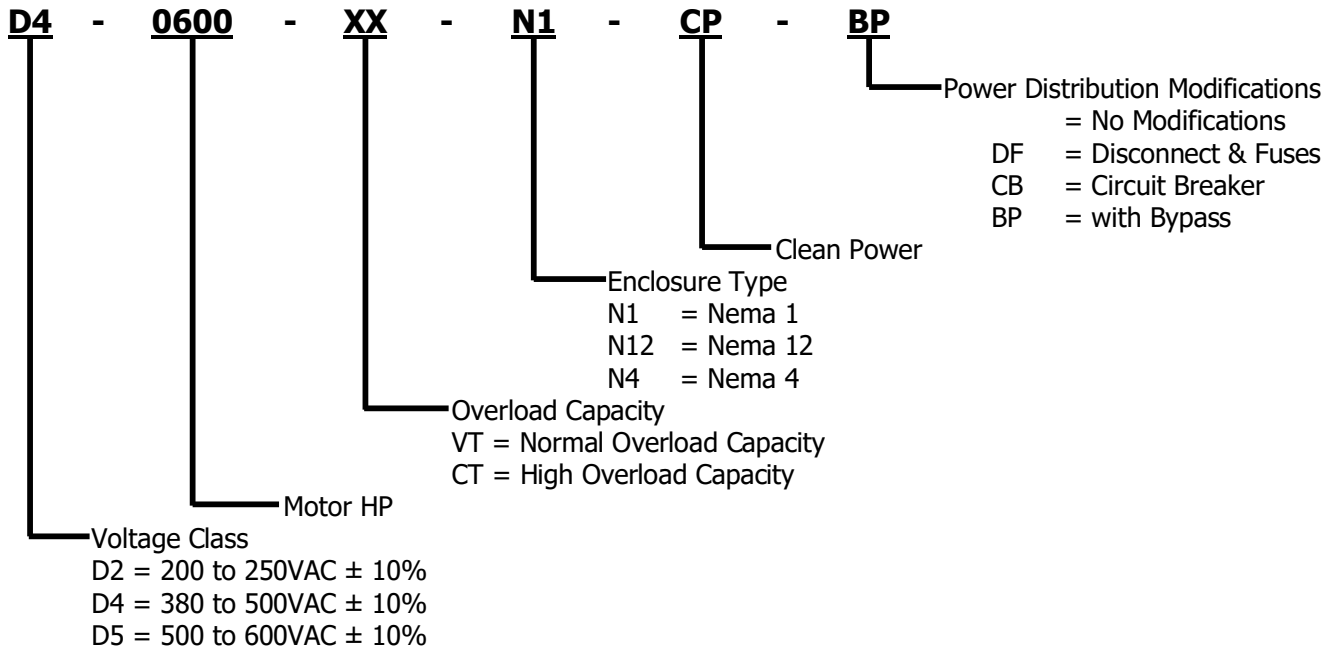

CATALOG NUMBER SELECTION / RATING TABLES

200-250VAC (-10% to +10%)							
Frame	NEMA 1 (IP20) Catalog Number ²	Motor HP ¹	Continuous Output Current (Amps) ^{3,4}	Output KVA ⁵	Input Current (Amps)	Input KVA ⁵	Maximum Recommended AC Line Fuses ⁶ (Amps)
SIZE 1	D2-0020XX-N1-CP	20	54	22	43	18	70
	D2-0025XX-N1-CP	25	68	28	54	23	90
	D2-0030XX-N1-CP	30	85	35	65	27	100
SIZE 2	D2-0040XX-N1-CP	40	104	43	87	36	150
	D2-0050XX-N1-CP	50	130	54	108	45	200
	D2-0060XX-N1-CP	60	163	68	130	54	250
	D2-0075XX-N1-CP	75	192	80	162	68	300
	D2-0100XX-N1-CP	100	248	103	217	90	300
SIZE 3	D2-0125XX-N1-CP	125	312	130	271	113	7
	D2-0150XX-N1-CP	150	360	150	325	135	7
	D2-0200XX-N1-CP	200	480	200	433	180	7
	D2-0250XX-N1-CP	250	602	250	541	225	7

¹ Horsepower rating based on 230 VAC Motors.

² "XX" = CT for High Overload Capacity Drives, "XX" = VT for Normal Overload Capacity Drives.

³ High Overload Capacity Drives (CT) produce 150% of Rated Drive Output Current for 1 minute.

⁴ Normal Overload Capacity Drives (VT) produce 120% of Rated Drive Output Current for 1 minute.

⁵ Output and Input KVA at nominal 240 VAC.

⁶ UL Class T, J and Semiconductor Fuses (preferred): Ferraz Shawmut A50Q, Bussmann FWH.

⁷ Included as standard.

CATALOG NUMBER SELECTION / RATING TABLES

380-500VAC (-10% to +10%)							
Frame	NEMA 1 (IP20) Catalog Number ²	Motor HP ¹	Continuous Output Current (Amps) ^{3,4}	Output KVA ⁵	Input Current (Amps)	Input KVA ⁵	Maximum Recommended AC Line Fuses ⁶ (Amps)
SIZE 1	D4-0040XX-N1-CP	40	52	43	43	36	70
	D4-0050XX-N1-CP	50	66	55	54	45	90
	D4-0060XX-N1-CP	60	82	68	65	54	100
SIZE 2	D4-0075XX-N1-CP	75	97	81	81	68	125
	D4-0100XX-N1-CP	100	124	103	108	90	175
	D4-0125XX-N1-CP	125	156	130	135	113	200
	D4-0150XX-N1-CP	150	180	150	162	135	250
	D4-0200XX-N1-CP	200	240	200	217	180	350
SIZE 3	D4-0250XX-N1-CP	250	302	251	271	225	?
	D4-0300XX-N1-CP	300	361	300	325	270	?
	D4-0350XX-N1-CP	350	414	344	379	315	?
	D4-0400XX-N1-CP	400	477	397	433	360	?
	D4-0450XX-N1-CP	450	540	449	487	405	?
SIZE 4	D4-0500XX-N1-CP	500	600	499	541	450	?
	D4-0600XX-N1-CP	600	720	599	650	540	?
	D4-0700XX-N1-CP	700	840	698	758	630	?
	D4-0800XX-N1-CP	800	960	798	866	720	?
	D4-0900XX-N1-CP	900	1080	898	974	810	?
	D4-1000XX-N1-CP	1000	1200	998	1083	900	?

Consult Factory for Higher HP Drives

¹ Horsepower rating based on 460 VAC Motors.

² "XX" = CT for High Overload Capacity Drives, "XX" = VT for Normal Overload Capacity Drives.

³ High Overload Capacity Drives (CT) produce 150% of Rated Drive Output Current for 1 minute.

⁴ Normal Overload Capacity Drives (VT) produce 120% of Rated Drive Output Current for 1 minute.

⁵ Output and Input KVA at nominal 480 VAC.

⁶ UL Class T and Semiconductor Fuses (preferred): Ferraz Shawmut A50Q, Bussmann FWH.

⁷ Included as standard.

CATALOG NUMBER SELECTION / RATING TABLES

500-600VAC (-10% to +10%)							
Frame	NEMA 1 (IP20) Catalog Number ²	Motor HP ¹	Continuous Output Current (Amps) ^{3,4}	Output KVA ⁵	Input Current (Amps)	Input KVA ⁵	Maximum Recommended AC Line Fuses ⁶ (Amps)
SIZE 1	D5-0040XX-N1-CP	40	41	41	35	36	60
	D5-0050XX-N1-CP	50	52	52	43	45	80
	D5-0060XX-N1-CP	60	65	65	52	54	90
	D5-0075XX-N1-CP	75	78	78	65	68	100
	D5-0100XX-N1-CP	100	99	99	87	90	150
SIZE 2	D5-0125XX-N1-CP	125	125	124	108	113	175
	D5-0150XX-N1-CP	150	157	156	136	135	200
	D5-0200XX-N1-CP	200	192	191	173	180	300
	D5-0250XX-N1-CP	250	242	241	217	225	7
	D5-0300XX-N1-CP	300	289	288	260	270	7
SIZE 3	D5-0350XX-N1-CP	350	336	335	303	315	7
	D5-0400XX-N1-CP	400	382	380	346	360	7
	D5-0450XX-N1-CP	450	432	430	390	405	7
	D5-0500XX-N1-CP	500	472	470	433	450	7
	D5-0600XX-N1-CP	600	576	574	520	540	7
	D5-0700XX-N1-CP	700	672	669	606	630	7
	D5-0800XX-N1-CP	800	768	765	693	720	7
SIZE 4	D5-0900XX-N1-CP	900	864	860	779	810	7
	D5-1000XX-N1-CP	1000	960	956	866	900	7
	D5-1200XX-N1-CP	1200	1152	1195	1039	1080	7
	Consult Factory for Higher HP Drives						

¹ Horsepower rating based on 575 VAC Motors.

² "XX" = CT for High Overload Capacity Drives, "XX" = VT for Normal Overload Capacity Drives.

³ High Overload Capacity Drives (CT) produce 150% of Rated Drive Output Current for 1 minute.

⁴ Normal Overload Capacity Drives (VT) produce 120% of Rated Drive Output Current for 1 minute.

⁵ Output and Input KVA at nominal 600 VAC.

⁶ UL Class T, CC and Semiconductor Fuses (preferred): Ferraz Shawmut A70Q, Bussmann FWP.

⁷ Included as standard.

Dimensions - Nema 1 Enclosed

Input Voltage	Motor HP	VFD Only		VFD with Disconnect & Fuses		VFD with Bypass	
		Approximate Dimensions (HxWxD)	Figure	Approximate Dimensions (HxWxD)	Figure	Approximate Dimensions (HxWxD)	Figure
200 - 250 VAC (208/230/240)	20 - 30	60" x 24" x 24"	1	60" x 24" x 24"	1	60" x 24" x 24"	1
	40 - 100	72" x 30" x 25"	1	72" x 30" x 25"	1	72" x 30" x 25"	2
	125 - 250	72" x 72" x 30"	2	72" x 72" x 30"	2	72" x 72" x 30"	3
	Above 250	Consult Factory	-	Consult Factory	-	Consult Factory	-
380 - 500 VAC (380/400/415/480)	40 - 60	60" x 24" x 24"	1	60" x 24" x 24"	1	60" x 24" x 24"	1
	75 - 200	72" x 30" x 25"	1	72" x 30" x 25"	1	72" x 30" x 25"	2
	250 - 500	72" x 72" x 30"	2	72" x 72" x 30"	2	72" x 72" x 30"	3
	600 - 1000	84" x 118" x 30"	3	84" x 118" x 30"	3	84" x 118" x 30"	-
	Above 1000	Consult Factory	-	Consult Factory	-	Consult Factory	-
525 - 600 VAC (525/575/600)	40 - 75	60" x 24" x 24"	1	60" x 24" x 24"	1	60" x 24" x 24"	1
	100 - 200	72" x 30" x 25"	1	72" x 30" x 25"	1	72" x 30" x 25"	2
	250 - 600	72" x 72" x 30"	2	72" x 72" x 30"	2	72" x 72" x 30"	3
	700 - 1200	84" x 118" x 30"	3	84" x 118" x 30"	3	84" x 118" x 30"	-
	Above 1200	Consult Factory	-	Consult Factory	-	Consult Factory	-

Dimensions - Nema 12 Enclosed

Input Voltage	Motor HP	VFD Only		VFD with Disconnect & Fuses		VFD with Bypass	
		Approximate Dimensions (HxWxD)	Figure	Approximate Dimensions (HxWxD)	Figure	Approximate Dimensions (HxWxD)	Figure
200 - 250 VAC (208/230/240)	20 - 30	60" x 24" x 24"	1	60" x 24" x 24"	1	60" x 24" x 24"	1
	40 - 100	72" x 30" x 25"	1	72" x 30" x 25"	1	72" x 30" x 25"	2
	125 - 250	72" x 72" x 30"	2	72" x 72" x 30"	2	72" x 72" x 30"	3
	Above 250	Consult Factory	-	Consult Factory	-	Consult Factory	-
380 - 500 VAC (380/400/415/480)	40 - 60	60" x 24" x 24"	1	60" x 24" x 24"	1	60" x 24" x 24"	1
	75 - 200	72" x 30" x 25"	1	72" x 30" x 25"	1	72" x 30" x 25"	2
	250 - 500	72" x 72" x 30"	2	72" x 72" x 30"	2	72" x 72" x 30"	3
	600 - 1000	84" x 118" x 30"	3	84" x 118" x 30"	3	84" x 118" x 30"	-
	Above 1000	Consult Factory	-	Consult Factory	-	Consult Factory	-
525 - 600 VAC (525/575/600)	40 - 75	60" x 24" x 24"	1	60" x 24" x 24"	1	60" x 24" x 24"	1
	100 - 200	72" x 30" x 25"	1	72" x 30" x 25"	1	72" x 30" x 25"	2
	250 - 600	72" x 72" x 30"	2	72" x 72" x 30"	2	72" x 72" x 30"	3
	700 - 1200	84" x 118" x 30"	3	84" x 118" x 30"	3	84" x 118" x 30"	-
	Above 1200	Consult Factory	-	Consult Factory	-	Consult Factory	-

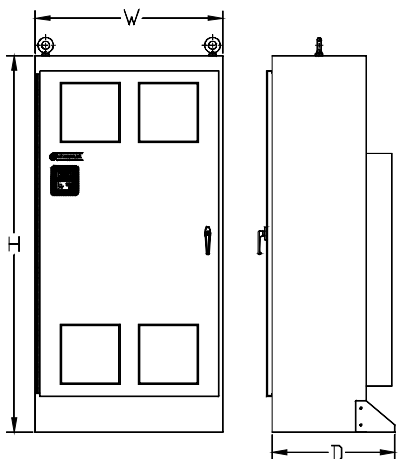

Figure 1

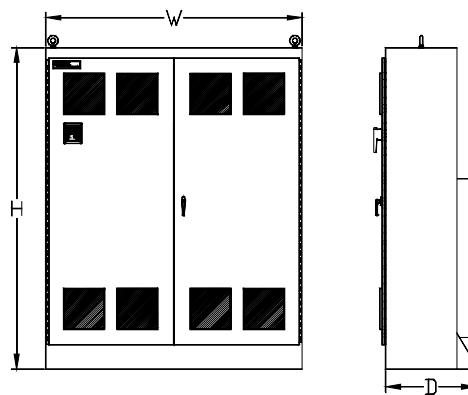

Figure 2

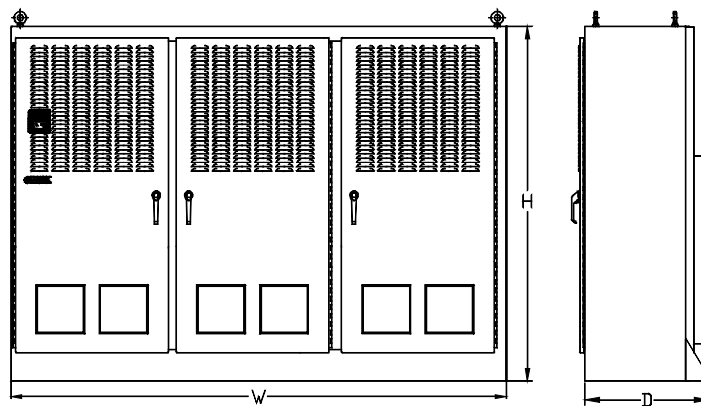

Figure 3