

REVISION		
REV.	DESCRIPTION	CHG. BY & DATE

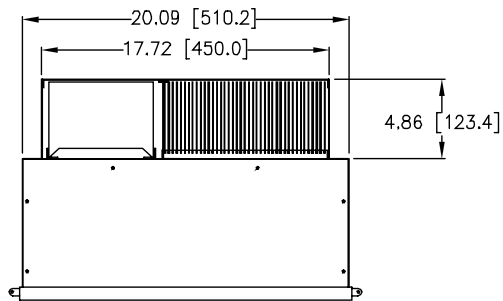

PANEL MOUNTING

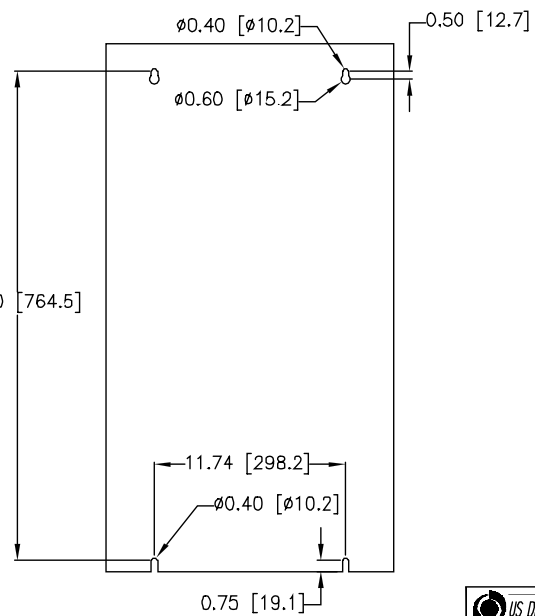
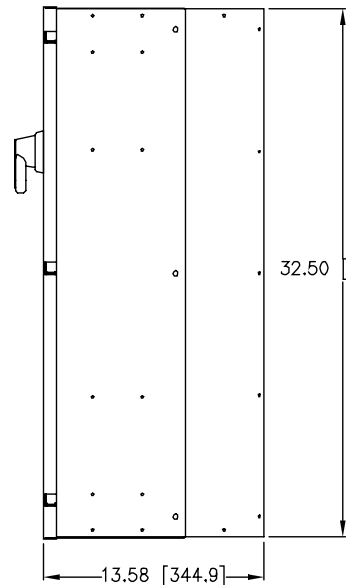
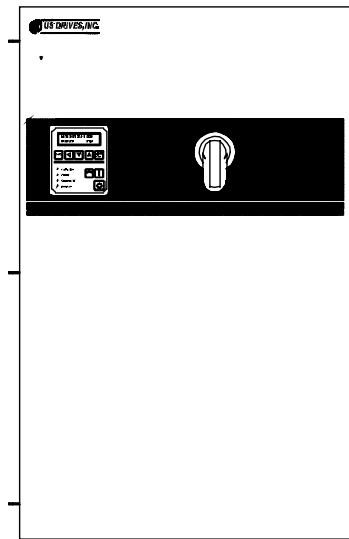

Approximate Weight: 190 Lbs. [86 Kgs]

This is AutoCAD drawing # SIZE 2-N12-DF

	DIMENSIONS IN INCHES	DR	12/11/06	APPD
	TOL. ± / FR	TITLE		
<small> US DRIVES, INC. CLAIMS PROPRIETARY RIGHTS IN ALL RIGHTS RESERVED. THE DESIGN OF THE PRODUCT IS THE PROPERTY OF US DRIVES, INC. ALL RIGHTS RESERVED. </small>	±.000	SIZE 2 NEMA TYPE 12 WITH DISCONNECT & FUSES		
<small> HOLE DIA. ±.003 </small>	ANGLES ±	SHT 1 OF 1		

Notes:

- Top and bottom endplates are removable to gain access inside the drive and to punch holes for conduits.
- End plates must be removed from the drive before drilling and punching holes to avoid metal dust inside the drive enclosure. Failure to do so will cause damage to the drive.